

Technical Data on Rod Ends and Spherical Bearings

Rod ends and spherical plain bearings are intended for linkage applications where a bearing must accommodate significant misalignment. While spherical plain bearings offer flexibility in housing and mounting design, the user bears the responsibility for housing design and the cost of housing manufacture. Rod ends offer greater mounting convenience and provide a compact, lightweight, economical design alternative to the spherical plain bearing. QBC offers a wide selection of rod ends and spherical bearings.

Rod End Construction

There are three basic rod end constructions. The *four-piece rod* end uses race inserts, typically of brass, to provide lubricity in the bearing area. This design offers reduced internal clearance, and provides smoother operation. It is ideal for dynamic applications. The *two-piece* rod end uses a rod end body which is formed around a spherical ball. The comparatively heavy cross section of the rod end body in the two-piece design provides high-strength. This makes the two-piece rod end ideal for highly loaded, static applications where high-strength is required. The *cartridge type* rod end consists of a spherical plain bearing mounted in a rod end body. This design allows the optimum selection of materials for ball, race and rod end body. The cartridge type rod end can also accommodate a PTFE liner for self-lubrication. This design is best suited for aircraft and military applications where material selection is a primary design consideration. While aircraft and military style components are not shown in this catalog, they are available from QBC on special order. The reader is encouraged to call for design assistance.

Self-lubricating Rod Ends

QBC offers metal-to-metal rod ends and self-lubricating rod ends. All metal-to-metal rod ends, including brass insert four-piece types, require regular lubrication. This can be accomplished by splash or immersion oil lubrication, or by greasing through optional lubricators (grease fittings). Self-

lubricating types are used where relubrication is not practical, or in applications where relubrication is not desirable, such as on food processing machinery or in clean environments. Self-lubricating rod ends are available with bonded PTFE fabric liners, or with molded, engineered thermoplastic race inserts.

Rod End Grades

Rod ends are offered in four grades: precision, commercial, aircraft and military. *Precision* rod ends are manufactured to tight tolerances for applications requiring improved linkage accuracy and reduced looseness. *Commercial* rod ends are produced using standard materials and manufacturing methods, and are an economical choice for industrial applications. *Aircraft* rod ends use premium materials, and have magnafluxed rod end bodies. Originally intended for aircraft applications, aircraft rod ends are used in many industrial applications where a high degree of reliability is required. *Military* rod ends are produced in strict accordance with all applicable military specifications and are typically used in military and commercial aviation applications, or when MIL-spec approval is required.

Precision Rod Ends Styles BRFHMP/BRFHFP four-piece precision rod ends use brass race inserts for lubricity and clearance control. They are produced to tight tolerances for applications requiring a more precise rod end; for example, a linkage where positioning accuracy is essential. These rod end bodies and balls are plated for corrosion resistance. Styles BRFHMX and BRFHFX four-piece precision extra capacity rod ends are the high-strength series intended for more heavily loaded, static and dynamic industrial applications. These rod ends have heat-treated bodies for increased strength and aluminum bronze race inserts for high bearing capacity. The rod end bodies are protective coated for corrosion resistance and the balls are chrome plated for superior wear and corrosion resistance. Series BR-FHMX (male) have oversized shanks for additional shank strength.

Commercial Rod Ends Series BRCHMC and BRCHF C four-piece commercial rod ends use the brass race insert design for lubricity and clearance control. These rod ends are preferred for dynamic applications. Our commercial rod ends have zinc plated bodies and nickel plated balls for corrosion resistance. Series BRCMCR and BRCFCR two-piece commercial rod ends offer high-strength for heavy static loads. The unique manufacturing process for two-piece rod ends yields the industry's best conformity between ball and body for maximum bearing capacity. Less expensive commercial rod ends are offered in the BRRODM and BRRODF series.

Aircraft Rod Ends Series* Four-piece aircraft rod ends have magnafluxed rod end bodies for a high degree of assurance of rod end integrity. The bearing surface is a chrome plated ball on brass race inserts. This series was originally intended for general aviation applications and is also used in many industrial applications where rod end reliability is critical. Special purpose aircraft rod ends use materials and construction identical to aircraft rod ends but have different dimensions. Self-lubricating aircraft rod ends use UNIFLON® PTFE liner and cartridge type construction. The UNIFLON® PTFE liner is approved to MIL-B-81820.

Military Rod Ends* Military rod ends use Type E UNIFLON® PTFE liner and cartridge type construction. Rod end bodies are made from 4340 alloy steel, heat-treated to MIL-H-6875, and are cadmium plated. The outer races are made from heat-treated 17-4PH stainless steel (AMS 5643). The balls are made from heat-treated 440C stainless steel (AMS 5630). The UNIFLON® PTFE liner is approved to MIL-B-81820, while our MIL-spec aircraft rod ends are approved to MIL-B-81935. These premium rod ends are primarily intended for use in commercial and military aviation applications.

Metric Rod Ends Four-piece, precision, metric rod ends, BRFSMGM and BRFSFGM series, use brass race inserts for lubricity and clearance control. They are produced to tight tolerances for applications

where a precision rod end is required in a metric size. Series BRCSMEM and BRCSFEM two-piece, self-lubricating metric rod ends, use Type E UNIFLON® PTFE liner. They are ideal for metric applications where relubrication is not practical. The two-piece construction offers the added benefit of high-strength for high loads. QBC also offers a wide variety of other metric rod ends. Contact QBC for availability and specifications.

Optional Rod End Features

















Rod ends are available with male and female threaded shanks. Standard rod ends are available in right-hand or left-hand threads. Lubricators are standard on selected series and are available as an option on all other series. Shank keyways are optionally available on most series to engage lock washer tangs. A wide range of other optional features includes plain shanks and special plating.



Military Specifications* Many of the processes used in the manufacture of rod ends are performed to U.S. Military Specifications. A partial list of these specifications follows:

Table 1 Military Specifications	
Process	Performed in accordance with:
Anodize	MIL-A-8625 Type 1 or 2
Cadmium Plate	QQ-P-416 Type 1 Class 2
Chrome Plate	QQ-C-320 Class 2 (.0002 min)
Heat Treat	MIL-H-6875 MIL-H-7199
Magnetic Particle Insp.	ASTM-E-1444
Penetrant Inspection	MIL-I-6866

***NOTE:** Aircraft and military style components are available on special order.

TABLE 2: ROD END SELECTION GUIDE

Series and Size Ranges		Product Features	Customer Benefits	Common Applications	Loading			Max. Temp. (°F)	Race Material
					Static	Oscillating	Reversing		
Inch	Metric	BRFSMGM BRFSFGM 5 - 25 mm	Low Friction, Long Dynamic Life Smooth Feel, Good Conformity	Control Linkages, For Reduced Play, Accelerator Linkages					Brass
Inch	Metric	Precision Grade Brass Inserts Four-Piece Construction	High Capacity Version	Heavy-Duty Applications					Aluminum Bronze
Inch	Metric	Precision Grade Aluminum Bronze Inserts, High-Strength Body Four-Piece Construction	High Loads Reversing Loads Shock Loads Cost-Effective	Brake and Clutch Pedals for Heavy Machinery, Satellite Dish Controls					Steel
Inch	Metric	BRRODM- BRRODF- 3/16 - 3/4"	High Loads Reversing Loads Shock Loads Cost-Effective	Brake and Clutch Pedals for Heavy Machinery, Satellite Dish Controls					Steel

 **Best**
 **Better**
 **Good**

Static Radial Load (See Figure 2)

The maximum static radial load permissible for a rod end depends on three factors: race material compressive strength, rod end head strength, and shank strength. The maximum static radial load is determined by taking the *lowest* of the three following values:

- Race material compressive strength (R)

$$R = E \cdot H \cdot X$$

- Rod end head strength (T)

Insert construction

$$T = [D - (E + .176 H)] \cdot H \cdot X$$

Cartridge type construction

$$T_1 = \left[\left(\frac{H}{2} \sqrt{D^2 - H^2} \right) + \left(\frac{D^2}{2} \cdot \sin^{-1} \frac{H}{D} \right) - (\text{O.D. of Bearing} \cdot H) \right] \cdot X$$

where angle of $\frac{H}{D}$ is expressed in radians.

- Shank strength (S)

Male threaded rod end

$$S = [(\text{root diameter of thread} \cdot .785) - (N^2 \cdot .785)] \cdot X$$

Female threaded rod end

$$S_1 = [(J^2 \cdot .785) - (\text{major diameter of thread} \cdot .785)] \cdot X$$

where:

- E = Ball diameter
- H = Housing width
- X = Allowable stress (see table)
- D = Head diameter
- N = Diameter of drilled hole in shank of male rod ends
- J = Shank diameter of female rod end

Static Axial Load* (See Figure 2)

The maximum available axial load for a rod end is determined by the following formula. This formula does not take into consideration bending of the shank due to a moment of force. Also, this formula does not consider the strength of the stake in cartridge type of construction:

- Axial strength (A)

$$A = .78 [(E + .176 H)^2 - E^2] \cdot X$$

where:

- X = Allowable stress (see table 3)
- E = Ball diameter
- H = Housing width

*Data also applies to spherical bearings.

Table 3 Material Stress*	
Material	Allowable Stress (PSI)
Brass	30000
Aluminum Bronze	35000
300 Series Stainless Steel	35000
Low Carbon Steel	52000
Alloy Steel	140000

Misalignment

The angle of misalignment in a rod end is controlled by the outside diameter of the head. The maximum degree of misalignment is obtained when the head contacts the side of the fork or clevis in which it is mounted.

Maximum misalignment is calculated by the following formula:

- Rod End Angle (α)

$$\alpha = \sin^{-1} \frac{W}{D} - \sin^{-1} \frac{H}{D}$$

where:

- D = Head diameter or diameter of outer race
- H = Housing width
- W = Ball width

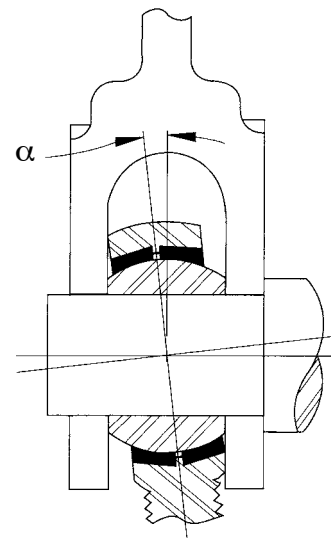
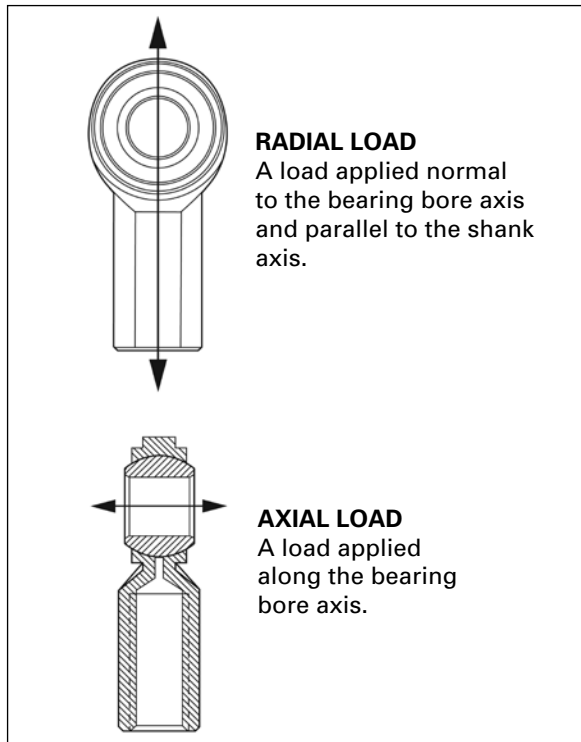

FIGURE 1

Rod End Bore (inch)	Misalignment +/- Degrees
.1900	6.5 (8.0)
.2500	8.0 (10.5)
.3125	7.0 (9.0)
.3750	6.0 (9.0)
.4375	7.0 (8.5)
.5000	6.0 (8.0)
.6250	8.0 (11.0)
.7500	7.0 (10.0)
1.0000	8.5 —

*These figures apply to all rod ends in this catalog except BRRODM and BRRODF series, which are in parentheses.

FIGURE 2
Studs

Studs are used in combination with rod ends to simplify mounting.

The stud is designed to accommodate up to $\pm 25^\circ$ misalignment in any direction and has a wrench flat to facilitate tightening. They are available on special order for BRFHMX, BRFHFX, BRCHMC, BRCHF, BRCMCR and BRCFCR series. Call for price and delivery information.

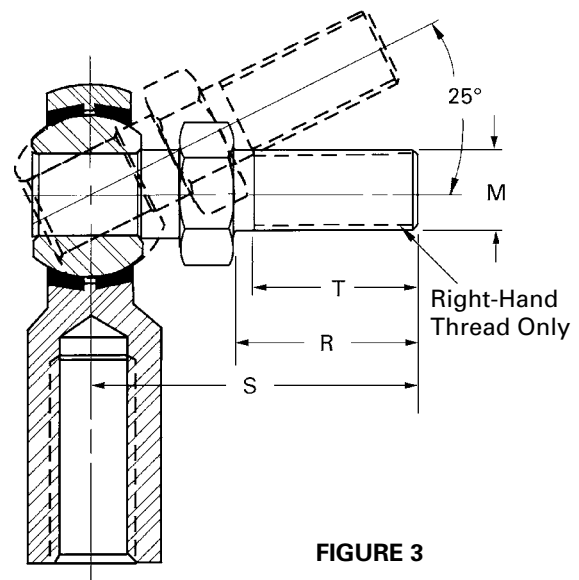
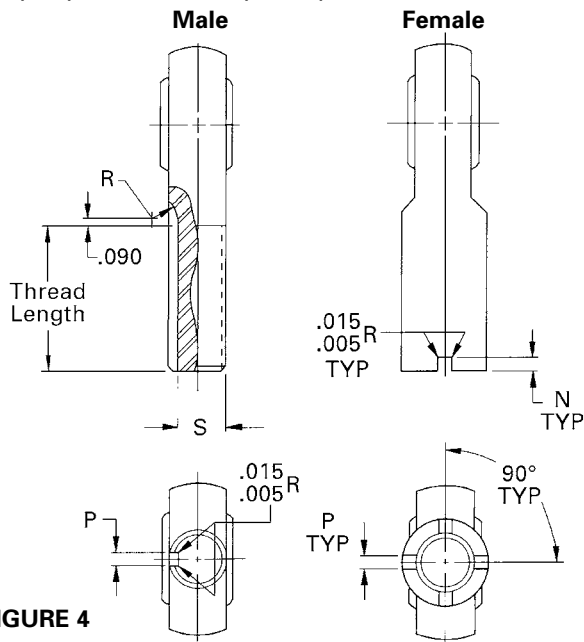

FIGURE 3

To Fit Rod End Bore Size	Dimensions in Inches			
	R	S	T	M
	$\pm .010$	$\pm .030$	REF	UNF-2A
.1900	.500	.969	.437	.1900-32
.2500	.562	1.047	.500	.2500-28
.3125	.687	1.234	.594	.3125-24
.3750	.906	1.540	.812	.3750-24
.4375	1.125	1.930	1.000	.4375-20
.5000	1.125	2.000	1.000	.5000-20
.6250	1.500	2.500	1.375	.6250-18
.7500	1.812	3.000	1.625	.7500-16

Studs available on special order.

Keyways

Keyway slots, where available, are determined as follows. Contact our Sales Department to determine keyway slot availability on a particular size.

FIGURE 4
Table 6 Rod End Keyway (Ref NAS 559)

Thread O.D. Reference	Dimensions in Inches			
	N	P	S	R
	+0.005 -0.000	+0.005 -0.000	+0.000 -0.005	REF
.2500	.056	.062	.201	.255
.3125	.056	.062	.260	.255
.3750	.056	.093	.311	.255
.4375	.069	.093	.370	.255
.5000	.069	.093	.436	.255
.5625	.077	.125	.478	.255
.6250	.077	.125	.541	.255
.7500	.077	.125	.633	.255
.8750	.086	.156	.777	.318
1.0000	.094	.156	.900	.318
1.1250	.094	.187	1.010	.382
1.2500	.116	.187	1.136	.382
1.3750	.116	.250	1.236	.445
1.5000	.116	.250	1.361	.445
1.6250	.129	.250	1.477	.445
1.7500	.129	.312	1.589	.508
1.8750	.129	.312	1.714	.508
2.0000	.129	.312	1.839	.508
2.1250	.129	.312	1.955	.508
2.2500	.129	.312	2.080	.508

Design Options

Rod Ends and Spherical Bearings can be ordered with the following design options at extra cost.

Table 7

Option	Available on Series
Keyway / Keyslot	BRFHMP- BRFHFP- BRFHMX- BRFHFX- BRCHMC- BRCHFC-
Zerk Type Lubricators	BRFHMP- BRFHFP- BRCHMC- BRCHFC-
Flush Type Lubricators	BRFHMP- BRFHFP- BRFHMX- BRFHFX- BRCHMC- BRCHFC-
300 Series Stainless Steel Inserts	BRFHMP- BRFHFP- BRFHMX- BRFHFX- BRCHMC- BRCHFC-
Stud	BRFHMP- BRFHFP- BRCHMC- BRCHFC-
Chrome Plated Balls	BPFLSX- (Spherical Bearings)
Cross Drilled Oil Hole	BPFLSS- BPSLHS- BPFLHA- BPFLHB- BPFCOM- (Spherical Bearings)

Table 8 Housing Bores					
Bearing Code	Bearing O.D. D	Housing Bore			
		Steel		Aluminum	
	+0.0000 -0.0005	Max.	Min.	Max.	Min.
BPFLSX Series					
030	.6250	.6245	.6241	.6244	.6239
040	.7500	.7495	.7491	.7494	.7489
050	.8750	.8745	.8741	.8744	.8739
060	1.0000	.9995	.9991	.9994	.9989
070	1.1875	1.1870	1.1865	1.1869	1.1863
080	1.3125	1.3120	1.3115	1.3119	1.3113
100	1.5625	1.5620	1.5613	1.5619	1.5611
120	2.2500	2.2495	2.2488	2.2494	2.2486
160	2.3750	2.3745	2.3738	2.3744	2.3736
190	2.6250	2.6245	2.6238	2.6244	2.6236
240	3.2500	3.2495	3.2488	3.2494	3.2486
300	4.0000	3.9995	3.9988	3.9994	3.9986
Series BPFLSS, BPSLHS, BPFLHA, BPFLHB, BPSLSE & BPF COM					
020	.4687	.4682	.4678	.4681	.4676
030	.5625	.5620	.5616	.5619	.5614
040	.6562	.6557	.6553	.6556	.6551
050	.7500	.7495	.7491	.7494	.7489
060	.8125	.8120	.8116	.8119	.8114
070	.9062	.9057	.9053	.9056	.9051
080	1.0000	.9995	.9991	.9994	.9989
090	1.0937	1.0932	1.0928	1.0931	1.0926
100	1.1875	1.1870	1.1866	1.1869	1.1864
120	1.4375	1.4370	1.4366	1.4369	1.4364
140	1.5625	1.5620	1.5616	1.5619	1.5614
160	1.7500	1.7495	1.7491	1.7494	1.7489

Misalignment Specifications

The angle of misalignment in a spherical bearing is calculated somewhat differently from that of the rod end because the housing is not spherical. There are three different types of mountings in which these bearings may be used as shown, and the angle of misalignment is governed by the type of mounting adopted.

Shown in **Figures 5, 6 and 7** are the common mountings for spherical bearings and the corresponding formula for calculating the angle of misalignment.

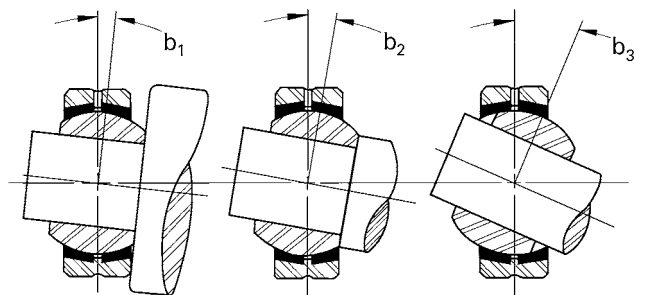

$$b_1 = \sin^{-1} \frac{W}{V} - \sin^{-1} \frac{H}{E}$$

$$b_2 = \sin^{-1} \frac{W}{E} - \sin^{-1} \frac{H}{E}$$

$$b_3 = \cos^{-1} \frac{B}{E} - \sin^{-1} \frac{H}{E}$$

FIGURE 5
FIGURE 6
FIGURE 7

Reference Letters:

B = Bore of ball

C = Chamfer on outer race

D = Bearing O.D.

E = Ball diameter

H = Housing width

$V = \sqrt{(D - 2C)^2 + H^2}$

W = Ball width

NOTE: See product page for dimensions.

Table 9 Misalignment Specifications			
Bearing Code	Maximum Misalignment (+/- Degrees)		
	b ₁	b ₂	b ₃
BPFLSX Series			
030	9.0	16.5	34.5
040	8.0	14.5	29.0
050	9.0	14.0	30.0
060	8.0	12.5	27.0
070	6.5	11.0	25.0
080	7.5	12.5	23.0
100	8.0	12.0	23.0
120	9.0	15.0	27.0
160	6.5	10.0	25.0
190	6.0	8.5	23.5
240	5.0	7.0	23.0
300	5.0	7.0	25.0
Series BPFLSS, BPSLHS, BPFLHA, BPFLHB, BPSLSE & BPF COM			
020	8.5	13.5	28.0
030	7.0	11.0	29.5
040	9.0	13.0	30.0
050	8.0	12.0	26.0
060	7.5	10.5	23.5
070	6.5	9.5	20.5
080	7.0	10.0	20.0
090	7.5	10.0	20.0
100	7.0	9.0	19.0
120	7.0	9.0	21.0
140	7.0	9.0	16.0
160	7.5	9.5	16.0