

INTRODUCTION

Ball and roller bearings are used widely in instruments and machines in order to minimize friction and power loss. While the concept of the ball bearing dates back at least to Leonardo da Vinci, their design and manufacture has become remarkably sophisticated.

This technology was brought to its present state of perfection only after a long period of research and development. The benefits of such specialized research can be obtained when it is possible to use a standardized bearing of the proper size and type. However, such bearings cannot be used indiscriminately without a careful study of the loads and operating conditions. In addition, the bearing must be provided with adequate mounting, lubrication and sealing.

Design engineers have usually two possible sources for obtaining information which they can use to select a bearing for their particular application:

- a) Textbooks
- b) Manufacturers' catalogs

Textbooks are excellent sources; however, they tend to be overly detailed and aimed at the student of the subject matter rather than the practicing designer. They, in most cases, contain information on how to design rather than how to select a bearing for a particular application.

Manufacturers' catalogs, in turn, are also excellent and contain a wealth of information which relates to the products of the particular manufacturer. These catalogs, however, fail to provide alternatives – which may divert the designer's interest to products not manufactured by them.

Our Company, however, provides the broadest selection of many types of bearings made by different manufacturers. For this reason, we are interested in providing a condensed overview of the subject matter in an objective manner, using data obtained from different texts, handbooks and manufacturers' literature. This information will enable the reader to select the proper bearing in an expeditious manner.

If the designer's interest exceeds the scope of the presented material, a list of references is provided at the end of the Technical Section.

At the same time, we are expressing our thanks and are providing credit to the sources which supplied the material presented here.

The information deals with:

- a) Rolling Contact Bearings
 - b) Sintered-Metal Sliding Contact Bearings
- and
- c) Plastic and Nonmetallic Sliding Contact Bearings

1.0 ROLLING CONTACT BEARINGS

1.1 General

Rolling contact bearings can be divided into three basic groups:

- a) Ball Bearings
 - b) Thrust Bearings
- and
- c) Roller Bearings

Each of these groups can further be divided into subgroups. Rather than enumerating the subgroups, they will be shown in **Fig. 1-1** and **Fig. 1-2**.

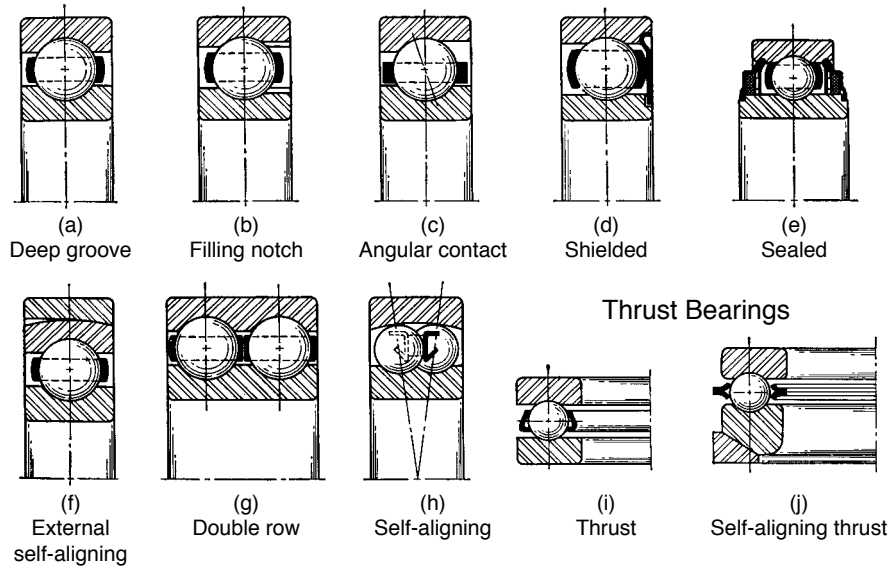

Fig. 1-1 Radial and Thrust Ball Bearings

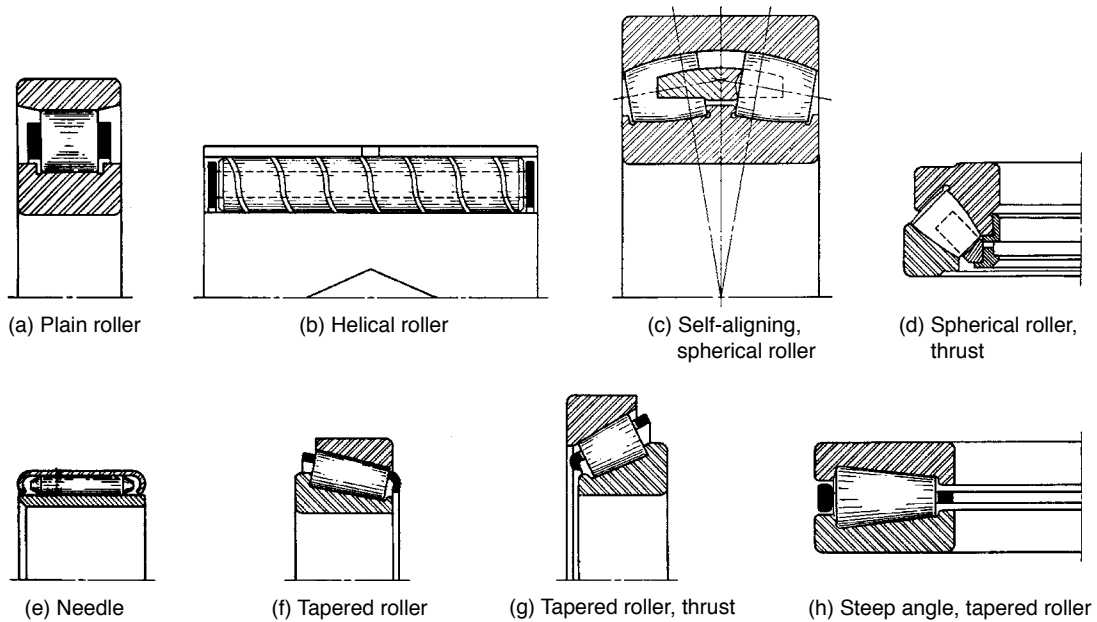

Fig. 1-2 Radial and Thrust Roller Bearings

1.2 Construction and Types of Ball Bearings

A ball bearing usually consists of four parts: an inner ring, an outer ring, the balls and the cage or separator. To increase the contact area and permit larger loads to be carried, the balls run in curvilinear grooves in the rings. The radius of the groove is slightly larger than the radius of the ball, and a very slight amount of radial play must be provided. The bearing is thus permitted to adjust itself to small amounts of angular misalignment between the assembled shaft and mounting. The separator keeps the balls evenly spaced and prevents them from touching each other on the sides where their relative velocities are the greatest.

Ball bearings are made in a wide variety of types and sizes. Single-row radial bearings are made in four series, extra light, light, medium, and heavy, for each bore, as illustrated in **Fig. 1-3(a), (b), and (c)**. The heavy series of bearings is designated by 400. Most, but not all, manufacturers use a numbering system so devised that if the last two digits are multiplied by 5, the result will be the bore in millimeters. The digit in the third place from the right indicates the series number. Thus, bearing 307 signifies a medium-series bearing of 35-mm bore. For additional digits, which may be present in the catalog number of a bearing, refer to manufacturer's details. Some makers list deep groove bearings and bearings with two rows of balls. For bearing designations of **Quality Bearings & Components (QBC)**, see special pages devoted to this purpose.

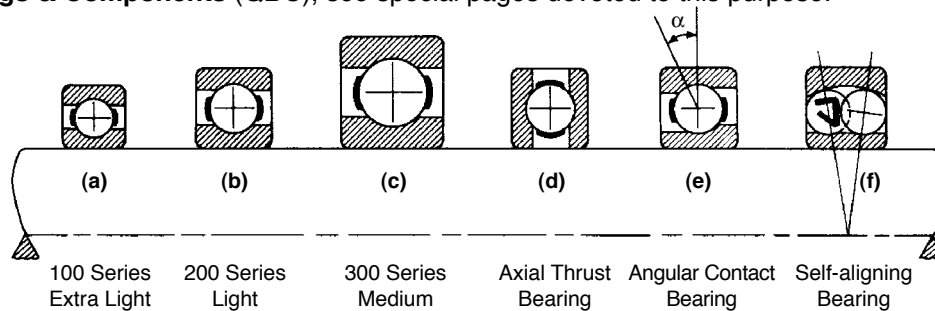

Fig. 1-3 Types of Ball Bearings

The radial bearing is able to carry a considerable amount of axial thrust. However, when the load is directed entirely along the axis, the thrust type of bearing should be used. The angular contact bearing will take care of both radial and axial loads. The self-aligning ball bearing will take care of large amounts of angular misalignment. An increase in radial capacity may be secured by using rings with deep grooves, or by employing a double-row radial bearing.

Radial bearings are divided into two general classes, depending on the method of assembly. These are the Conrad, or nonfilling-notch type, and the maximum, or filling-notch type. In the Conrad bearing, the balls are placed between the rings as shown in **Fig. 1-4(a)**. Then they are evenly spaced and the separator is riveted in place. In the maximum-type bearing, the balls are inserted through a filling notch ground into each ring, as shown in **Fig. 1-4(b)**. Because more balls can be

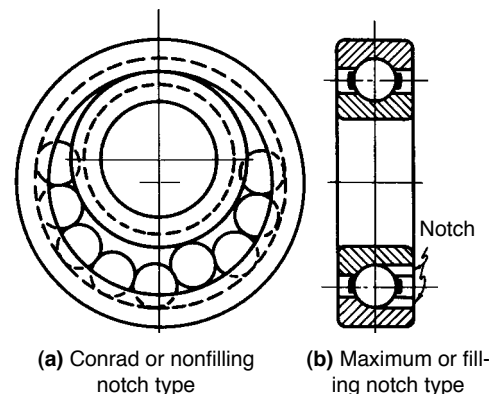

Fig. 1-4 Methods of Assembly for Ball Bearings

placed in such bearings, their load capacity is greater than that of the Conrad type. However, the presence of the notches limits the load-carrying capacity of these bearings in the axial direction.

High-carbon chromium steel 52100 and 440C stainless steel are used for balls and rings, and are treated to high strength and hardness. The surfaces are smoothly ground and polished. The commonly accepted minimum hardness for bearing components is 58 Rockwell C. This material is not suitable for temperatures over 350° F. For higher temperatures, steels especially developed for high-temperature service should be used. The dimensional tolerances are very small; the balls must be very uniform in size. The stresses are extremely high because of the small contact areas, and the yield point of the material may be exceeded at certain points. Because of the high values of the fluctuating stresses, antifriction bearings are not designed for unlimited life, but for some finite period of service determined by the fatigue strength of the materials. A specified speed and number of hours of expected service must therefore accompany the given load values for these bearings.

1.3 Bearing Selection Factors

Bearings are basically antifriction devices. For this reason, the friction characteristics of different bearing types have to be examined.

In addition to the rolling resistance, other factors which contribute to the friction are as follows:

1. Sliding between the rolling elements and the race. When the rolling elements are curved, all points in contact do not have the same linear velocity, because of their differing radii of rotation. In Fig. 1-5, for example, a point A on the ball will have a definite linear velocity if no sliding occurs. However, a second point B on the ball will have less linear velocity than A because of its smaller radius of rotation. But point B on the race actually has a slightly greater linear velocity than A. This introduces sliding in both backward and forward directions. Other factors which introduce sliding are the inevitable inaccuracies in geometry and other deviations from true rolling.
2. The sliding action between the rolling element and the separator. Although contact takes place at the poles, where the velocity is lowest, some sliding action is present.
3. In roller bearings, the sliding action between the rolling elements and the guide flanges.
4. The losses between the bearing parts and the lubricant and between the different particles of the lubricant.

Palmgren¹ gives the following frictional coefficients for antifriction bearings:

Self-aligning ball bearings	f = 0.0010
Cylindrical roller bearing	f = 0.0011
Thrust ball bearings	f = 0.0013
Single-row deep-groove ball bearings	f = 0.0015
Tapered and spherical roller bearings	f = 0.0018
Needle bearings	f = 0.0045

All these coefficients are referred to the bearing bore. They are for run-in bearings, under

¹ See reference at the end of the Technical Section.

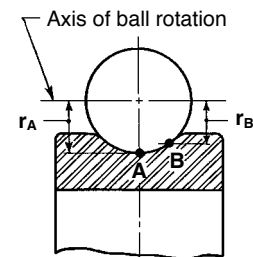

Fig. 1-5 Sliding caused by Geometry of Bearing

normal conditions, with good lubrication. When determining the total losses in a given application, the seal friction must not be ignored since it may be considerable.

In addition to considerations related to friction, attention must be given to speed requirements. Permissible speeds are influenced by bearing size, properties, lubrication detail and operating temperatures. The permissible speed varies inversely with mean bearing diameter.

Some guidelines for selecting bearings can be summarized as follows:

- Ball bearings are the less expensive choice in the smaller sizes and under lighter loads, while roller bearings are less expensive for larger sizes and heavier loads.
- Roller bearings are more satisfactory under shock or impact loading than ball bearings.
- Ball-thrust bearings are for pure thrust loading only. At high speeds, a deep-groove or angular-contact ball bearing usually will be a better choice, even for pure thrust loads.
- Self-aligning ball bearings and cylindrical roller bearings have very low friction coefficients.
- Deep-groove ball bearings are available with seals built into the bearing so that the bearing can be prelubricated to operate for long periods without attention.

The following **Table 1-1** attempts to summarize and tabulate various considerations which influence the selection of the appropriate bearings:

Relative rating

- good
- ▣ intermediate
- ◐ poor
- ◑ none
- ⊠ does not apply
- not available or known

NOTE: This table is only a general guide – ratings may change when considering special types or treatments.

Table 1-1 Bearing Selection Factors*

Selection Factors	Bearing Types																											
	Ball						Roller						Journal						Thrust				Ext. press.⑤		Gas ⑥			
	2a	2b	2c	2d	2e	2f	3a	3b	3c	3d	3e	3f	8a	8b	8c	8d	8e	8f	12a	12b	12c	12d	capillary ⑥	variable flow	pneumostatic	pneumodynamic		
Low starting friction	■	■	■	■	■	■	■	■	■	■	■	■	■	■	■	■	■	■	■	■	■	■	■	■	■	■	■	■
Low running friction	■	■	■	■	■	■	■	■	■	■	■	■	■	■	■	■	■	■	■	■	■	■	■	■	■	■	■	■
Low noise	◐	◐	◐	◐	◐	◐	◐	◐	◐	◐	◐	◐	◐	◐	◐	◐	◐	◐	◐	◐	◐	◐	◐	◐	◐	◐	◐	◐
Small diameter ①	◐	◐	◐	◐	◐	◐	◐	◐	◐	◐	◐	◐	◐	◐	◐	◐	◐	◐	◐	◐	◐	◐	◐	◐	◐	◐	◐	◐
Short length ①	◐	◐	◐	◐	◐	◐	◐	◐	◐	◐	◐	◐	◐	◐	◐	◐	◐	◐	◐	◐	◐	◐	◐	◐	◐	◐	◐	◐
High accuracy	◐	◐	◐	◐	◐	◐	◐	◐	◐	◐	◐	◐	◐	◐	◐	◐	◐	◐	◐	◐	◐	◐	◐	◐	◐	◐	◐	◐
Most available	◐	◐	◐	◐	◐	◐	◐	◐	◐	◐	◐	◐	◐	◐	◐	◐	◐	◐	◐	◐	◐	◐	◐	◐	◐	◐	◐	◐
High radial load ②	◐	◐	◐	◐	◐	◐	◐	◐	◐	◐	◐	◐	◐	◐	◐	◐	◐	◐	◐	◐	◐	◐	◐	◐	◐	◐	◐	◐
High thrust load ②	◐	◐	◐	◐	◐	◐	◐	◐	◐	◐	◐	◐	◐	◐	◐	◐	◐	◐	◐	◐	◐	◐	◐	◐	◐	◐	◐	◐
High dynamic load ②	◐	◐	◐	◐	◐	◐	◐	◐	◐	◐	◐	◐	◐	◐	◐	◐	◐	◐	◐	◐	◐	◐	◐	◐	◐	◐	◐	◐
Tolerate misalignment	◐	◐	◐	◐	◐	◐	◐	◐	◐	◐	◐	◐	◐	◐	◐	◐	◐	◐	◐	◐	◐	◐	◐	◐	◐	◐	◐	◐
Tolerate dirt	◐	◐	◐	◐	◐	◐	◐	◐	◐	◐	◐	◐	◐	◐	◐	◐	◐	◐	◐	◐	◐	◐	◐	◐	◐	◐	◐	◐
Low initial cost	◐	◐	◐	◐	◐	◐	◐	◐	◐	◐	◐	◐	◐	◐	◐	◐	◐	◐	◐	◐	◐	◐	◐	◐	◐	◐	◐	◐
High speed	◐	◐	◐	◐	◐	◐	◐	◐	◐	◐	◐	◐	◐	◐	◐	◐	◐	◐	◐	◐	◐	◐	◐	◐	◐	◐	◐	◐
High temperature ③	◐	◐	◐	◐	◐	◐	◐	◐	◐	◐	◐	◐	◐	◐	◐	◐	◐	◐	◐	◐	◐	◐	◐	◐	◐	◐	◐	◐
Simple lube system	◐	◐	◐	◐	◐	◐	◐	◐	◐	◐	◐	◐	◐	◐	◐	◐	◐	◐	◐	◐	◐	◐	◐	◐	◐	◐	◐	◐
High stability ④	⊠	⊠	⊠	⊠	⊠	⊠	⊠	⊠	⊠	⊠	⊠	⊠	⊠	⊠	⊠	⊠	⊠	⊠	⊠	⊠	⊠	⊠	⊠	⊠	⊠	⊠	⊠	⊠
Easy for designer	◐	◐	◐	◐	◐	◐	◐	◐	◐	◐	◐	◐	◐	◐	◐	◐	◐	◐	◐	◐	◐	◐	◐	◐	◐	◐	◐	◐

① with a given load (radial or thrust) ② with a given size ③ above 450°F ④ applies to high speed fluid-film bearings
 ⑤ journal or thrust type ⑥ restrictor controlled (liquid)

* See reference at the end of the Technical Section.

1.4 Bearing Loads

The first step in sizing a suitable ball bearing for a given application is the determination of the loads which it has to support. In this section, we list some of the most frequently occurring mechanical configurations and the bearing loads imposed by them.

(a) Radial Shaft Load Between Bearings

P = radial load
 R_1, R_2 = bearing loads
 l_1, l_2 = distances from radial load to bearings

$$R_1 = \frac{l_2 P}{l_1 + l_2} \quad (1)$$

$$R_2 = \frac{l_1 P}{l_1 + l_2} \quad (2)$$

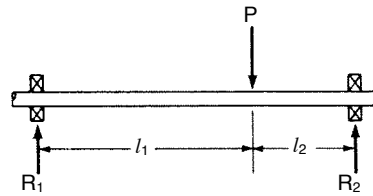

Fig. 1-6 Radial Load Between Bearings

(b) Overhung Radial Load

Notation same as in paragraph (a).

$$R_1 = \frac{l_2 P}{l_1 - l_2} \quad (3)$$

$$R_2 = \frac{l_1 P}{l_1 - l_2} \quad (4)$$

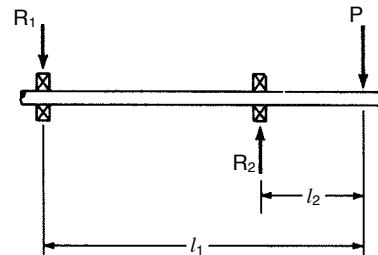

Fig. 1-7 Overhung Radial Load

For cases other than those shown above, the rules of static distribution of loads on a beam should be considered. The shaft which is supported by bearings is nothing else but a beam subjected to forces which result in radial loading of bearings.

1.5 Determination of Bearing Size

(a) Basic Definitions

In the course of many years of experience with ball bearings and extensive testing, it has been found that the prediction of the load capacity of a ball bearing is a statistical event related to the fatigue life of the bearing. This makes the sizing of ball bearings more difficult than that of many other machine elements.

A basic phenomenon in ball bearings is that ball bearing life has been found to be inversely proportional to the cube of the bearing load. This means that when the load is doubled, the life expectancy of the bearing is reduced by a factor of eight. This phenomenon has been studied extensively and has led to the adoption of an industry-wide national standard for rating ball bearings pioneered by the American Bearing Manufacturers Association (formerly Anti-Friction Bearing Manufacturers Association, Inc.), 1200 19th Street, N.W., Suite 300, Washington, D.C. 20036-2433.

The following represents a summary of the load rating of ball bearings of less than one inch in diameter, according to ANSI-AFBMA Standard 9-1978: "Load Rating and Fatigue Life for Ball Bearings" – reprinted with the permission of the American National Standards Institute, Inc., 11 West 42nd Street, 13th Floor, New York, N.Y. 10036.

Ball bearings were formerly rated on the basis of the compressive stress in the most heavily loaded ball. Except for static loads, experience has shown that the actual cause of failure is fatigue. Fatigue characteristics are thus used for load rating and are dependent to a large extent on experimental results.

The life of a ball bearing is the life in hours at some known speed, or the number of revolutions, that the bearing will attain before the first evidence of fatigue appears on any of the moving elements. Experience has shown that the life of an individual ball bearing cannot be precisely predicted. Fatigue characteristics are thus used for load ratings.

Even if ball bearings are properly mounted, adequately lubricated, protected from foreign matter, and are not subject to extreme operating conditions, they can ultimately fatigue. Under ideal conditions, the repeated stresses developed in the contact areas between the balls and the raceways eventually can result in fatigue of the material which manifests itself as spalling of the load carrying surfaces. In most applications, the fatigue life is the maximum useful life of a bearing. This fatigue is the criterion of life used as the basis for the first part of this standard.

The material in the standard which follows assumes bearings having nontruncated contact area, hardened good quality steel as the bearing material, adequate lubrication, proper ring support and alignment, nominal internal clearances, and adequate groove radii. In addition, certain high-speed effects such as ball centrifugal forces and gyroscopic moments are not considered.

The following nomenclature and definitions are used in life testing of bearings. A multitude of identical bearings are tested under same conditions:

RATING LIFE is the life at which 10 percent of bearings have failed and 90 percent of them are still good. This value is designated as L_{10} and is expressed in millions of revolutions.

LIFE of an individual ball bearing is the number of revolutions (or hours at some given constant speed) designated as L which the bearing runs before the first evidence of fatigue develops in the material of either ring (or washer) or of any of the rolling elements.

MEDIAN LIFE is the life at which 50 percent of bearings failed and 50 percent are still good. It is designated as L_{50} , which is generally not more than five times the RATING LIFE, L_{10} .

BASIC LOAD RATING "C" for a radial or angular contact ball bearing is the calculated, constant, radial load which a group of apparently identical bearings with stationary outer ring can theoretically endure for a RATING LIFE of one million revolutions of the inner ring. For a thrust ball bearing, it is the calculated, constant, centric, thrust load which a group of apparently identical bearings can theoretically endure for a RATING LIFE of one million revolutions of one of the bearing washers. The basic load rating is a reference value only of the base value of one million revolutions RATING LIFE having been chosen for ease of calculation. Since applied loading as great as the basic load rating tends to cause local plastic deformation of the rolling surfaces, it is not anticipated that such heavy loading would normally be applied.

(b) Determination of Basic Load Rating

The basic load rating C for a rating life of one million revolutions for radial and angular contact ball bearings, except filling slot bearings, with balls not larger than 1 in. diameter, is given by the equation:

$$C = f_c(i \cos \alpha)^{0.7} Z^{2/3} D^{1.8} \quad (\text{lbs.}) \quad (5)$$

where:

- i = number of rows of balls in the bearing
- α = nominal angle of contact (angle between line of action of ball load and plane perpendicular to bearing axis)
- Z = number of balls per row

D = ball diameter

f_c = a constant from **Table 1-2**, as determined by the value of $(D \cos \alpha)/d_m$

d_m = pitch diameter of ball races

NOTE: For balls larger than 1 inch diameter, the exponent for D is 1.4.

To get a better feel for the meaning of one million revolutions, it is attained in 8 hrs at a speed of 2,084 rpm. Most ball bearings, however, may have intended life many times exceeding one million revolutions.

In the above formula, d_m represents the pitch diameter of the ball races. It can be expressed as follows:

$$d_m = \frac{A - B}{2} + B = \frac{A + B}{2} \quad (6)$$

A and B are dimensions as shown. However, assuming that inner ring and outer ring wall thicknesses are the same, A becomes outside diameter, and B the bore of the bearing.

Values of f_c are shown in **Table 1-2** for different values of $(D \cos \alpha)/d_m$.

RATING LIFE L_{10} in millions of revolutions for a ball bearing application can be calculated from:

$$L_{10} = \left(\frac{C}{P}\right)^3 \quad (7)$$

where:

C = the basic load rating as previously defined

and P = the load.

(c) Illustrative Examples

Example 1

Consider an ABEC 3 single row, radial ball bearing having 10 balls of 1/16 diameter, 0.300 inner race diameter and 0.452 outer race diameter in a single shield configuration.

$\alpha = 0^\circ$ (radial bearing)

Z = 10 (number of balls)

D = 1/16 (ball diameter)

and $d_m = \frac{1}{2} (0.300 + 0.452) = 0.391$ (pitch diameter of ball races).

Therefore, $\left(\frac{D \cos \alpha}{d_m}\right) = \frac{0.062 \times 1}{0.391} = 0.16$

From **Table 1-2** this value yields (from third column) a value of $f_c=4530$. Substituting these values in Equation (5) for C, we obtain:

$$C = 4530 \times 1 \times 10^{2/3} \times 0.062^{1.8} = 143 \text{ lbs}$$

This means that for a load of P = 143 lbs, the rating life of this ball bearing will be one million revolutions and 90% of a group of such ball bearings will be expected to complete or exceed this value.

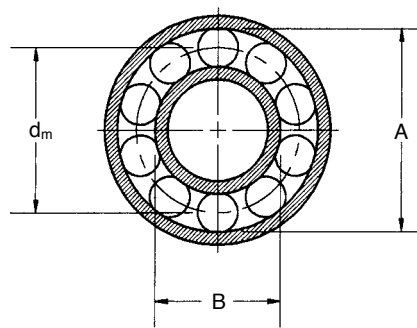

Table 1-2* Values of f_c

$\frac{D \cos \alpha}{d_m}$	Single Row Radial Contact; Single & Double Row Angular Contact, Groove Type ⁽¹⁾		Double Row Radial Contact Groove Type		Self-Aligning	
	Metric ⁽²⁾	Inch ⁽³⁾	Metric ⁽²⁾	Inch ⁽³⁾	Metric ⁽²⁾	Inch ⁽³⁾
0.05	46.7	3550	44.2	3360	17.3	1310
0.06	49.1	3730	46.5	3530	18.6	1420
0.07	51.1	3880	48.4	3680	19.9	1510
0.08	52.8	4020	50.0	3810	21.1	1600
0.09	54.3	4130	51.4	3900	22.3	1690
0.10	55.5	4220	52.6	4000	23.4	1770
0.12	57.5	4370	54.5	4140	25.6	1940
0.14	58.8	4470	55.7	4230	27.7	2100
0.16	59.6	4530	56.5	4290	29.7	2260
0.18	59.9	4550	56.8	4310	31.7	2410
0.20	59.9	4550	56.8	4310	33.5	2550
0.22	59.6	4530	56.5	4290	35.2	2680
0.24	59.0	4480	55.9	4250	36.8	2790
0.26	58.2	4420	55.1	4190	38.2	2910
0.28	57.1	4340	54.1	4110	39.4	3000
0.30	56.0	4250	53.0	4030	40.3	3060
0.32	54.6	4160	51.8	3950	40.9	3110
0.34	53.2	4050	50.4	3840	41.2	3130
0.36	51.7	3930	48.9	3730	41.3	3140
0.38	50.0	3800	47.4	3610	41.0	3110
0.40	48.4	3670	45.8	3480	40.4	3070

NOTES:

- (1) a. When calculating the basic load rating for a unit consisting of two similar, single row, radial contact ball bearings, in a duplex mounting, the pair is considered as one, double row, radial contact ball bearing.
- b. When calculating the basic load rating for a unit consisting of two, similar, single row, angular contact ball bearings in a duplex mounting, "Face-to-Face" or "Back-to-Back", the pair is considered as one, double row, angular contact ball bearing.
- c. When calculating the basic load rating for a unit consisting of two or more similar, single angular contact ball bearings mounted "in Tandem", properly manufactured and mounted for equal load distribution, the rating of the combination is the number of bearings to the 0.7 power times the rating of a single row ball bearing. If the unit may be treated as a number of individually interchangeable single row bearings, this footnote (1) c. does not apply.
- (2) Use to obtain C in newtons when D is given in mm.
- (3) Use to obtain C in pounds when D is given in inches.

*Reprinted by permission of the American National Standards Institute, 11 West 42nd Street, 13th Floor, New York, NY 10036. (from ANSI-AFBMA Std. 9-1978)

Suppose now it is desired to determine the “L” life of this bearing when operating at 200 rpm and a load of 50 lbs, the life being evaluated in hours of operation.

Let the life in hours be denoted by L, and let N denote the rpm of the bearing. We then have:

$$L = \frac{10^6 L_{10}}{60 N} = \left(\frac{C}{P} \right)^3 \frac{10^6}{60 N} \quad (8)$$

Substituting N = 200, P = 50 and C = 143 into Equation (8), we obtain L = 1949 hours.

NOTE: L₁₀ is bearing life in millions of revolutions; L is bearing life in hours.

A table showing required life at constant operating speed has been given by N. Chironis (“Today’s Ball Bearings”, *Product Engineering*, December 12, 1960, pp. 63-77, table on p. 68). This table is reproduced below with the permission of McGraw-Hill Book Company, New York, N.Y.

Table 1-3 Required Life at Constant Operating Speed
 (data from SKF Industries)

Type of Machine	Life in Hours of Operation
Instruments and apparatus which are only infrequently used. Ex.: demonstration apparatus, devices for operation of sliding doors.	500
Aircraft Engines.	500–2000
Machines for service of short duration or intermittent operation, where service interruptions are of minor importance. Ex.: hand tools, lifting tackle in machinery shops, hand-driven machines in general, farm machinery, assembly cranes, charging machines, foundry cranes, household machines.	4000–8000
Machines for intermittent service where dependable operation is of great importance. Ex.: auxiliary machines in power stations, conveying-equipment in production lines, elevators, general-cargo cranes, machine tools less frequently used.	8000–12000
Machines for 8-hour service which are not always fully utilized. Ex.: machines in general in the mechanical industries, cranes for continuous service, blowers, jackshafts.	20000–30000
Machines for continuous operation (24-hour service). Ex.: separators, compressors, pumps, mainline shafting, roller beds and conveyor rollers, mine hoists, stationary electric motors.	40000–60000
Machines for 24-hour service where dependability is of great importance. Ex.: pulp and paper machines, public power stations, mine pumps, public pumping stations, machines for continuous service aboard ships.	100000–200000

In order to provide data for larger size bearings as well as additional examples, **Table 1-4** is given.

Table 1-4 Dimensions and Basic Load Ratings for Conrad-Type Single-Row Radial Ball Bearings

Bearing No.	Bore		Outside Diameter		Width		Balls		Capacity, lbs	
	mm	inch	mm	inch	mm	inch	No. Z	Dia. D	Dynamic C	Static P _{st}
102	15	0.5906	32	1.2598	9	0.3543	9	3/16	965	550
202			35	1.3780	11	0.4331	7	1/4	1340	760
302			42	1.6535	13	0.5118	8	17/64	1660	930
103	17	0.6693	35	1.3780	10	0.3937	10	3/16	1040	640
203			40	1.5748	12	0.4724	7	5/16	1960	1040
303			47	1.8504	14	0.5512	6	3/8	2400	1240
104	20	0.7874	42	1.6535	12	0.4724	9	1/4	1620	980
204			47	1.8504	14	0.5512	8	5/16	2210	1280
304			52	2.0472	15	0.5906	7	3/8	2760	1530
105	25	0.9843	47	1.8504	12	0.4724	10	1/4	1740	1140
205			52	2.0472	15	0.5906	9	5/16	2420	1520
305			62	2.4409	17	0.6693	8	13/32	3550	2160
106	30	1.1811	55	2.1654	13	0.5118	11	9/32	2290	1590
206			62	2.4409	16	0.6299	9	3/8	3360	2190
306			72	2.8346	19	0.7480	8	1/2	5120	3200
107	35	1.3780	62	2.4409	14	0.5512	11	5/16	2760	2010
207			72	2.8346	17	0.6693	9	7/16	4440	2980
307			80	3.1496	21	0.8268	8	17/32	5750	3710
108	40	1.5748	68	2.6772	15	0.5906	13	5/16	3060	2450
208			80	3.1496	18	0.7087	9	1/2	5640	3870
308			90	3.5433	23	0.9055	8	5/8	7670	5050
109	45	1.7717	75	2.9528	16	0.6299	13	11/32	3630	2970
209			85	3.3465	19	0.7480	9	1/2	5660	3980
309			100	3.9370	25	0.9843	8	11/16	9120	6150
110	50	1.9685	80	3.1496	16	0.6299	14	11/32	3770	3260
210			90	3.5433	20	0.7874	10	1/2	6070	4540
310			110	4.3307	27	1.0630	8	3/4	10680	7350
111	55	2.1654	90	3.5433	18	0.7087	13	13/32	4890	3950
211			100	3.9370	21	0.8268	10	9/16	7500	5710
311			120	4.7244	29	1.1417	8	13/16	12350	8660
112	60	2.3622	95	3.7402	18	0.7087	14	13/32	5090	4560
212			110	4.3307	22	0.8661	10	5/8	9070	6890
312			130	5.1181	31	1.2205	8	7/8	14130	10100
113	65	2.5591	100	3.9370	18	0.7087	15	13/32	5280	4950
213			120	4.7244	23	0.9055	10	11/16	10770	8460
313			140	5.5118	33	1.2992	8	15/16	16010	11600
114	70	2.7559	110	4.3307	20	0.7874	14	15/32	6580	6080
214			125	4.9213	24	0.9449	10	11/16	10760	8740
314			150	5.9055	35	1.3780	8	1	18000	13260

Example 2:

Find the value of C for a 207 radial bearing.

Solution:

By **Table 1-4**: $d_m = \frac{1}{2} (2.8346 + 1.3780) = 2.1063$ in

$$\frac{D \cos \alpha}{d_m} = \frac{0.4375}{2.1063} = 0.208$$

By **Table 1-2**: $f_c = 4550$

By **Table 1-4**: $D = \frac{7}{16} = 0.4375$ in

$$\begin{aligned} \log D &= 9.64098 - 10 \\ 1.8 \log D &= 9.35376 - 10 \\ D^{1.8} &= 0.2258 \\ Z = 9, \quad Z^{2/3} &= \sqrt[3]{9^2} = 4.327 \end{aligned}$$

From Equation (5) for C: $C = 4550 \times 4.327 \times 0.2258 = 4440$ lbs,
 load for 1 million revolutions with
 90 percent probability that it will
 be attained or exceeded.

(d) Relationship between Load and Number of Revolutions

In some cases, it is needed to determine the new value of the permitted loading when the number of revolutions N is changed.

Experimentally, it was proven that:

$$\frac{N_1}{N_2} = \frac{P_2^3}{P_1^3} \quad (9)$$

where N is number of revolutions and P is radial load.

Furthermore, it was established that

$$10^6 C^3 = N_1 P_1^3 = N_2 P_2^3 = N_3 P_3^3 \dots \text{is a constant,}$$

or subsequently: $N_1 = \frac{10^6 C^3}{P_1^3} \quad (10)$

It has to be made clear that C is the basic load rating in lbs for a rating life of 1 million revolutions, and this fact establishes the above relationship.

If a bearing has a rating life expressed in number of revolutions designated by N, the life of the bearing expressed in hours, designated by L, can be found from:

$$N = 60 n L$$

where n is the actual speed in rpm of the bearing.

Example 3

For Example 2 where we found $C = 4440$ lbs, find the radial load P_1 for a rating life of 500 hours, at 1500 rpm.

$$P_1^3 = \frac{10^6 C^3}{N_1} = \frac{10^6 C^3}{60 n L}$$

Apply: $C = 4.440$ lbs, $n = 1500$ rpm, and $L = 500$ hrs

$$P_1^3 = \frac{10^6 \times 4.440^3}{60 \times 1500 \times 500} = 1.945 \cdot 10^6$$

$$P_1 = 10^2 \times \sqrt[3]{1.945} = 1250 \text{ lbs}$$

(e) Combined Axial and Radial Loads

This condition is dealt with by ANSI-AFBMA Standard 9-1978 which defines the combined load to be expressed as:

$$P = C_1 (X \cdot i \cdot F_r + Y \cdot F_a) \quad (11)$$

Table 1-5 Shock and Impact Factors

Type of Load	C_1
Constant or steady	1.0
Light shocks	1.5
Moderate shocks	2.0
Heavy shocks	3.0 and up

where value C_1 is a service factor which is shown in **Table 1-5**.

In the above equation:

i = race rotation factor equal 1 for inner ring rotation, 1.2 for outer ring rotation.

F_r and F_a are radial and axial components, respectively, of the load.

X and Y are factors to be used as shown in **Table 1-6**.

NOTE: Y is the axial or thrust factor determined from the value of

$$\frac{F_a}{i Z D^2}$$

Table 1-6 Values of X and Y

Bearing Type				Single Row Bearings		Double Row Bearings											
				$(F_a/F_r) > e$		$(F_a/F_r) \leq e$		$(F_a/F_r) > e$		e							
				X	Y	X	Y	X	Y								
Radial Contact Groove Ball Bearings	$\frac{F_a}{C_o}$	$\frac{F_a}{i Z D^2}$		0.56	2.30	1	0	0.56	2.30	0.19							
		Newtons	lbf														
	0.014	0.172	25														
	0.028	0.345	50														
	0.056	0.689	100														
	0.084	1.03	150														
	0.11	1.38	200														
	0.17	2.07	300														
	0.28	3.45	500														
	0.42	5.17	750														
0.56	6.89	1000															
Angular Contact Groove Ball Bearings with Contact Angle 5°	$\frac{F_a}{C_o}$	$\frac{F_a}{i Z D^2}$		For this type use the X, Y and e values applicable to single row radial contact bearings.		1	0.78	0.78	2.78	0.23							
		Newtons	lbf														
	0.014	0.172	25														
	0.028	0.345	50														
	0.056	0.689	100														
	0.085	1.03	150														
	0.11	1.38	200														
	0.17	2.07	300														
	0.28	3.45	500														
	0.42	5.17	750														
0.56	6.89	1000															
10°	0.014	0.172	25	0.46	1.88	1	0.75	0.75	2.18	0.29							
	0.029	0.345	50														
	0.057	0.689	100														
	0.086	1.03	150														
	0.11	1.38	200														
	0.17	2.07	300														
	0.29	3.45	500														
	0.43	5.17	750														
	0.57	6.89	1000														
15°	0.015	0.172	25	0.44	1.47	1	0.72	0.72	1.65	0.38							
	0.029	0.345	50														
	0.058	0.689	100														
	0.087	1.03	150														
	0.12	1.38	200														
	0.17	2.07	300														
	0.29	3.45	500														
	0.44	5.17	750														
	0.58	6.89	1000														
20°			0.43	1.00	1	0.65	0.65	0.65	1.63	0.57							
25°			0.41	0.87													
30°			0.39	0.76													
35°			0.37	0.66													
40°			0.35	0.57													
Self-aligning Ball Bearings				0.40	$0.40 \cot \alpha$	1	$0.42 \cot \alpha$	0.65	$0.65 \cot \alpha$	$1.5 \tan \alpha$							

- (1) Two similar, single row, angular contact ball bearings mounted "Face-to-face" or "Back-to-back" are considered as one, double row, angular contact bearing.
- (2) Values of X, Y and e for a load or contact angle other than shown in **Table 5-5** are obtained by linear interpolation.
- (3) Values of X, Y and e shown in **Table 5-5** do not apply to filling slot bearings for applications in which ball-raceway contact areas project substantially into the filling slot under load.
- (4) For single row bearings, when $F_a/F_r \leq e$, use $X = 1$ and $Y = 0$.

*Reprinted by permission of the American National Standards Institute, 11 West 42nd Street, 13th Floor, New York, NY 10036 (for ANSI-AFBMA Std. 9-1978).

Example 4

For a bearing dealt with in Example 2, assume that it carries a combined load of 400 lbs radially and 300 lbs axially at 1200 rpm. The outer ring rotates, and the bearing is subjected to moderate shock. Find the rating life of this bearing in hours.

Solution:

$$\frac{F_a}{i Z D^2} = \frac{300}{9 \times 0.4375^2} = 174$$

$$Y = 1.50$$

$$C_1 = 2$$

$$P = 2(0.56 \times 1.2 \times 400 + 1.5 \times 300) = 1440 \text{ lbs equivalent radial load}$$

$$N = \frac{10^6 C^3}{P^3} = 60 n L$$

$$L = \frac{10^6 C^3}{60 n P^3} = \frac{10^6 \times 4440^3}{60 \times 1200 \times 1440^3} = 410 \text{ hr, it will be attained or exceeded.}$$

life with 90 percent probability that

NOTE: The impact load on a bearing should not exceed the static capacity as given by **Table 1-4** or the race may be damaged by Brinelling from the balls. This load may be exceeded somewhat if the bearing is rotating and the duration of the load is sufficient for the bearing to make one or more complete revolutions while the load is acting.

Example 5

What change in the loading of a ball bearing will cause the expected life to be doubled?

Solution:

Let N_1 and P_1 be the original life and load for the bearing. Let N_2 and P_2 be the new life and load.

Then: $N_2 = 2N_1$

By Equation (9):

$$P_2^3 = \frac{N_1 P_1^3}{N_2} = \frac{N_1 P_1^3}{2N_1} = 0.5 P_1^3$$

$$P_2 = \sqrt[3]{0.5 \times P_1} \quad \text{or}$$

$$P_2 = 0.794 P_1$$

Hence a reduction of the load to 79 percent of its original value will cause a doubling of the expected life of a ball bearing.

(f) Variable Loading of Bearings

Ball bearings frequently operate under conditions of variable load and speed. Design calculations should take into account all portions of the work cycle and should not be based solely on the most severe operating conditions. The work cycle should be divided into a number of portions in each of which the speed and load can be considered as constant.

Suppose P_1, P_2, \dots are the loads on the bearing for successive intervals of the work cycle. Let

N_1 be the life of the bearing, in revolutions, if operated exclusively at the constant load P_1 . Let there be N_1' applications of load P_1 . Then N_1'/N_1 represents the proportion of the life consumed in this portion of the cycle.

Let N_2 be the life of the bearing, in revolutions, if operated exclusively at load P_2 . Let there be N_2' applications of load P_2 . Then N_2'/N_2 represents the proportion of the life consumed by load P_2 .

A corresponding statement can be made for each portion of the work cycle. The sum of these proportions represents the total life of the bearing or unity. Then:

$$\frac{N_1'}{N_1} + \frac{N_2'}{N_2} + \frac{N_3'}{N_3} + \dots = 1 \quad (12)$$

Let N_c be the life of the bearing under the combined loading. Let $N_1' = \alpha_1 N_c$ where α_1 represents the proportion of the total life, consumed under load P_1 . In a similar way, $N_2' = \alpha_2 N_c$, $N_3' = \alpha_3 N_c$, and so on. Substitution in Equation (12) yields:

$$\frac{\alpha_1}{N_1} + \frac{\alpha_2}{N_2} + \frac{\alpha_3}{N_3} + \dots = \frac{1}{N_c}$$

Using Equation (10):

$$N_1 = \frac{10^6 C^3}{P_1^3}, \quad N_2 = \frac{10^6 C^3}{P_2^3}, \dots \text{ and so on.}$$

Combining these last two equations we can obtain:

$$\frac{1}{N_c} = \frac{\alpha_1 P_1^3}{10^6 C^3} + \frac{\alpha_2 P_2^3}{10^6 C^3} + \dots, \text{ or multiplying both sides of the equation by } 10^6 C^3$$

$$\frac{10^6 C^3}{N_c} = \alpha_1 P_1^3 + \alpha_2 P_2^3 + \dots \quad (13)$$

From previous definition of α it is obvious that $\alpha_1 + \alpha_2 + \dots$ must equal unity. The application of this equation will be demonstrated by the following examples.

Example 6

A ball bearing is to operate on the following work cycle:

Radial load of 1400 lbs at 200 rpm for 25% of the time

Radial load of 2000 lbs at 500 rpm for 20% of the time

Radial load of 800 lbs at 400 rpm for 55% of the time

Total rpm is to be 1100.

Additional conditions:

The inner ring rotates; loads are steady. Find the minimum value of the basic rating load C for a suitable bearing for this application if the required life is 7 years at 4 hours per day.

	Assumed interval, min	rpm	In assumed interval, rev.
$P_1 = 1400$ lbs	0.25	200	50
$P_2 = 2000$ lbs	0.20	500	100
$P_3 = 800$ lbs	0.55	400	220
	1.00		370 rpm

Since both the load as well as the speed for the particular load varies, we have to establish the actual work cycle per minute.

The following table should be constructed:

$$\text{Then } \alpha_1 = \frac{50}{370}, \alpha_2 = \frac{100}{370}, \alpha_3 = \frac{220}{370}$$

A working year is assumed to consist of 250 days.

Total life duration of the bearing expressed in hours will become $7 \times 250 \times 4 = 7000$ hours, whereas this expressed in number of revolutions becomes:

$$N_c = 7000 \times 60 \times 370 = 1554 \times 10^5 \text{ revolutions.}$$

Inputting this data in the formula (13), previously derived in **1.5 (f)**:

$$\frac{10^6 C^3}{N_c} = \alpha_1 P_1^3 + \alpha_2 P_2^3 + \alpha_3 P_3^3 \dots,$$

$$\text{we obtain: } \frac{50}{370} \times 1400^3 + \frac{100}{370} \times 2000^3 + \frac{220}{370} \times 800^3 = (3708 + 21622 + 3044) \times 10^5$$

$$\frac{10^6 C^3}{N_c} = 28374 \times 10^5$$

$$\frac{C^3}{N_c} = 2837.4$$

$$C^3 = 2837.4 \times N_c = 2837.4 \times 1554 \times 10^5 = 44093 \times 10^7$$

$$C = 7610 \text{ lbs}$$

In order to choose the appropriate bearing, we refer to **Table 1-4** from which we find that a bearing such as No. 308 should be satisfactory, keeping in mind there is but a 90 percent probability that the required life will be attained or exceeded.

Example 7

A 306 radial ball bearing with inner ring rotation has a 10-sec work cycle as follows:

For 2 seconds	For 8 seconds
$F_r = 800 \text{ lbs}$	$F_r = 600 \text{ lbs}$
$F_a = 400 \text{ lbs}$	$F_a = 0 \text{ lbs}$
$n = 900 \text{ rpm}$	$n = 1200 \text{ rpm}$
Light shock	Steady load

Find the rating life of this bearing in hours and in years of 250 working days of 2 hours each.

Solution:

Since the bearing chosen is No. 306, from **Table 1-4**:

$$Z = 8, D = 0.5 \text{ and } i = 1.$$

$$\frac{F_a}{i Z D^2} = \frac{400}{1 \times 8 \times 0.5^2} = 200$$

From Table 1-6 for this value of 200, a value for Y will be 1.45 and X will be 0.56.

From Equation (11) and **Table 1-5**, for the combined axial and radial loads with light shock and 2-second duration:

$$P_1 = C_1 (X_i F_r + Y F_a) = 1.5 (0.56 \times 1 \times 800 + 1.45 \times 400)$$

$$P_1 = 1542 \text{ lbs (equivalent radial load)}$$

Since P_2 is a pure radial load:

$$P_2 = F_r = 600 \text{ lbs}$$

The number of revolutions for the 2-second time duration will be:

$$\frac{900}{60} \times 2 = 30$$

whereas for the 8-second time duration will be:

$$\frac{1200}{60} \times 8 = 160$$

The combined total number of revolutions in 10 seconds is:

$$30 + 160 = 190$$

then,

$$\alpha_1 = \frac{30}{190} = \frac{3}{19}, \quad \alpha_2 = \frac{160}{190} = \frac{16}{19}$$

From formula (13)

$$\frac{10^6 C^3}{N_c} = \alpha_1 P_1^3 + \alpha_2 P_2^3$$

Using $C = 5120$ in **Table 1-4** for bearing No. 306:

$$\frac{10^6 \times 5120^3}{N_c} = \frac{3}{19} \times 1542^3 + \frac{16}{19} \times 600^3 = 578.9 \times 10^6 + 181.9 \times 10^6 = 760.8 \times 10^6$$

$$N_c = \frac{5120^3}{760.8} = \frac{134218 \times 10^6}{760.8} = 176 \times 10^6 = L_{10} \times 10^6$$

This is the number of revolutions the bearing will endure. The total number of revolutions during the 10-second operation was established as being 190. Therefore, the number of revolutions per minute will be:

$$n = \frac{190}{10} \times 60 = 1140 \text{ rpm}$$

From Equation (8):

$$L = \frac{10^6 L_{10}}{60 \times n} = \frac{175 \times 10^6}{60 \times 1140} = 2558 \text{ hours}$$

This expressed in years of operation will become

$$\frac{2558}{2 \times 250} = 5.12 \text{ years of life with 90 percent probability of service, assuming 2 hours of operation per day}$$

(g) Static Loading of Bearings

Up to this point we have been dealing with dynamic loading of bearings. This is the condition when there is relative motion between the rings of the bearings and the balls that are rotating. If this is not the case, as a result of static concentrated loads of the balls against the races, the depressions of the balls into the races will gradually enlarge, and permanent indentations will remain. The static capacity is ordinarily defined as the maximum allowable static load that does not impair the running characteristics of the bearing to make it unusable.

This permanent deformation under the balls is known as Brinnelling and takes place at moderate to high loads. The magnitude of the permissible load is found by methods given in the standards. Calculations for the bearings of **Table 1-4** have been made and are shown in the column headed P_{st} .

When very smooth and quiet operation is required, the loading should be no more than about one-half the static capacity.

Back and forth rotation of the shaft through small angles can cause early failure of bearings unless the load is very light. Lubrication is difficult because the oil or grease may not be replenished back of a ball or roller before the motion is reversed.

(h) Effect of Increased Confidence Levels

When a bearing is installed, there is no way of knowing whether it is one of the 90 percent that are good or one of the 10 percent that will not attain the rating life. In other words, one can have but 90 percent confidence that the bearing will achieve or exceed its rating life, usually designated L_{10} .

In some cases, a greater degree of reliability is required. The expected life will of course be reduced as the reliability is made higher. Let an adjusting factor a_1 be taken such that life L_n is equal to $a_1 L_{10}$. Factors a_1 for different values of the reliability are given in **Table 1-7**. Life L_{10} is the rating life.

Table 1-7 Constants for Designing at Different Confidence Levels

Reliability (%)	L_n	Life Adjustment Factor, a_1
90	L_{10}	1.00
95	L_5	0.62
96	L_4	0.53
97	L_3	0.44
98	L_2	0.33
99	L_1	0.21

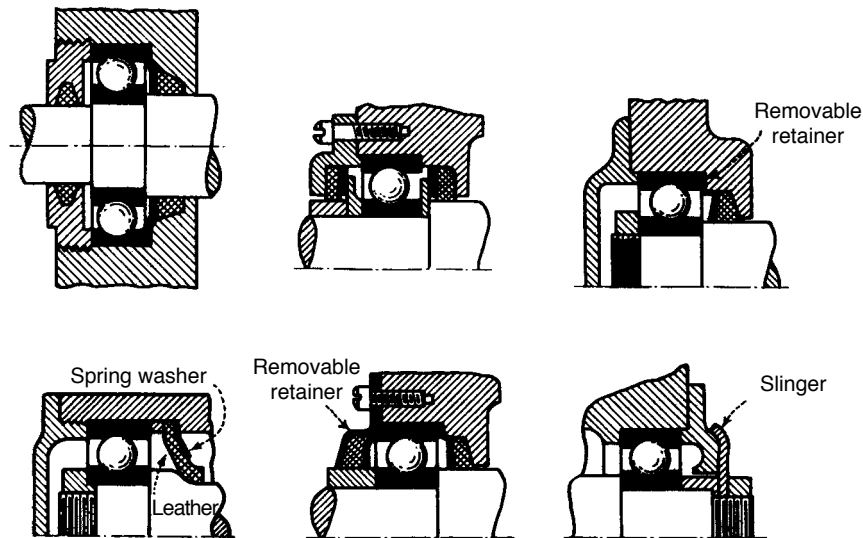

Fig. 1-8

1.6 Mounting of Ball Bearings

For a rotating shaft, relative rotation between shaft and bearing is usually prevented by mounting the inner ring with a press fit and securing it with a nut threaded on the shaft. Excessive interference of metal must be avoided in press fits, or the stretching of the inner ring may decrease the small but requisite internal looseness of the bearing.

The tolerances for shafts and housings as a function of their respective sizes are given in **Tables 1-8** and **1-9**. Please note that the nominal sizes are given in millimeters, however, the tolerances themselves are given in inches.

Although the outer ring, when the shaft rotates, is mounted more loosely than the inner ring, rotational creep between the ring and housing should be prevented. When two bearings are mounted on the same shaft, the outer ring of one of them should be permitted to shift axially to care for any differential expansion between shaft and housing. Several examples of typical mounting details with oil retainers are shown in **Fig. 1-8**. The catalogs of the various manufacturers contain useful illustrations of this kind, as well as other practical information.

Shafts or spindles in machine tools and precision equipment that must rotate without play or clearance in either the radial or axial directions can be mounted on preloaded ball bearings. The preloading, which removes all play from the bearing, can be secured in a number of different ways. For example, suppose the outer rings of the bearings at **A** in **Fig. 1-9** project a small but controlled amount beyond the inner rings. When the inner rings are brought into contact at **B** by means of the locknut, the balls will be displaced in the rings an amount sufficient

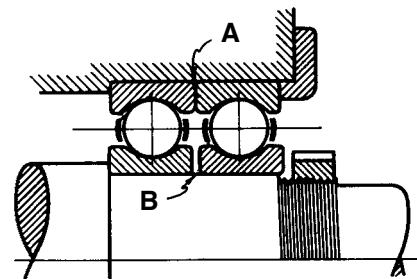

Fig. 1-9 Method for obtaining preloading in ball bearings

Table 1-8 Deviation of Shaft Diameters from Nominal Dimensions (inches)

Fit inner ring to shaft		Push fit	Push fit to wringing fit	Wringing fit	Drive fit		Light force fit		Force fit		Heavy force fit	
Nominal dia. (mm)		g6	h6	h5	j5	j6	k5	k6	m5	m6	n6	p6
Over	Incl.											
3	6	-0.0002 -0.0005	0 -0.0003	0 -0.0002	+0.0002 -0.0000							
6	10	-0.0002 -0.0006	0 -0.0004	0 -0.0002	-0.0002 -0.0006	-0.0003 -0.0001						
10	18	-0.0002 -0.0007	0 -0.0004	0 -0.0003	-0.0002 -0.0007	-0.0003 -0.0001	-0.0004 -0.0000	-0.0005 -0.0000				
18	30	-0.0003 -0.0008	0 -0.0005	0 -0.0004	-0.0003 -0.0008	-0.0004 -0.0002	-0.0004 -0.0001	-0.0006 -0.0001	-0.0007 -0.0003	-0.0008 -0.0003	-0.0011 -0.0006	
30	50	-0.0004 -0.0010	0 -0.0006	0 -0.0004	-0.0004 -0.0010	-0.0004 -0.0002	-0.0005 -0.0001	-0.0007 -0.0001	-0.0008 -0.0004	-0.0010 -0.0004	-0.0013 -0.0007	-0.0017 -0.0010
50	80	-0.0004 -0.0011	0 -0.0007	0 -0.0005	-0.0004 -0.0011	-0.0005 -0.0003	-0.0006 -0.0001	-0.0008 -0.0001	-0.0009 -0.0004	-0.0012 -0.0004	-0.0015 -0.0008	-0.0020 -0.0013
80	120	-0.0005 -0.0013	0 -0.0009	0 -0.0006	-0.0005 -0.0013	-0.0005 -0.0004	-0.0007 -0.0001	-0.0010 -0.0001	-0.0011 -0.0005	-0.0014 -0.0005	-0.0018 -0.0009	-0.0023 -0.0015
120	180	-0.0006 -0.0015	0 -0.0010	0 -0.0007	-0.0006 -0.0015	-0.0006 -0.0004	-0.0008 -0.0001	-0.0011 -0.0001	-0.0013 -0.0006	-0.0016 -0.0006	-0.0020 -0.0011	-0.0027 -0.0017

Table 1-9 Deviation of Housing Bores from Nominal Dimensions (inches)

Fit inner ring to shaft		Close running fit	Slide fit		Push fit		Wringing fit		Drive fit		Heavy drive fit		Light force fit	
Nominal dia. (mm)		G7	H8	H7	J7	J6	K6	K7	M6	M7	N6	N7	P6	P7
Over	Incl.													
10	18	-0.0002 -0.0009	0 -0.0011	0 -0.0007	-0.0003 -0.0004	-0.0002 -0.0002	-0.0004 -0.0001	-0.0005 -0.0002	-0.0006 -0.0002	-0.0007 0	-0.0008 -0.0004	-0.0009 -0.0002	-0.0010 -0.0006	-0.0011 -0.0004
18	30	-0.0003 -0.0011	0 -0.0013	0 -0.0008	-0.0004 -0.0005	-0.0002 -0.0003	-0.0004 -0.0001	-0.0006 -0.0002	-0.0007 -0.0002	-0.0008 0	-0.0009 -0.0004	-0.0011 -0.0003	-0.0012 -0.0007	-0.0014 -0.0006
30	50	-0.0004 -0.0013	0 -0.0015	0 -0.0010	-0.0004 -0.0006	-0.0002 -0.0004	-0.0005 -0.0001	-0.0007 -0.0003	-0.0008 -0.0002	-0.0010 0	-0.0011 -0.0005	-0.0013 -0.0003	-0.0015 -0.0008	-0.0017 -0.0007
50	80	-0.0004 -0.0016	0 -0.0018	0 -0.0012	-0.0005 -0.0007	-0.0002 -0.0005	-0.0006 -0.0002	-0.0008 -0.0004	-0.0009 -0.0002	-0.0012 0	-0.0013 -0.0006	-0.0015 -0.0004	-0.0018 -0.0010	-0.0020 -0.0008
80	120	-0.0005 -0.0019	0 -0.0021	0 -0.0014	-0.0005 -0.0009	-0.0002 -0.0006	-0.0007 -0.0002	-0.0010 -0.0004	-0.0011 -0.0002	-0.0014 0	-0.0015 -0.0004	-0.0018 -0.0004	-0.0020 -0.0012	-0.0023 -0.0009
120	180	-0.0006 -0.0021	0 -0.0025	0 -0.0016	-0.0006 -0.0010	-0.0003 -0.0007	-0.0008 -0.0002	-0.0011 -0.0005	-0.0013 -0.0003	-0.0016 0	-0.0018 -0.0008	-0.0020 -0.0005	-0.0024 -0.0014	-0.0027 -0.0011
180	250	-0.0006 -0.0024	0 -0.0028	0 -0.0018	-0.0006 -0.0012	-0.0003 -0.0009	-0.0009 -0.0002	-0.0013 -0.0005	-0.0015 -0.0003	-0.0018 0	-0.0020 -0.0009	-0.0024 -0.0006	-0.0028 -0.0016	-0.0031 -0.0013
250	315	-0.0007 -0.0027	0 -0.0032	0 -0.0020	-0.0006 -0.0014	-0.0003 -0.0010	-0.0011 -0.0002	-0.0014 -0.0006	-0.0016 -0.0004	-0.0020 0	-0.0022 -0.0010	-0.0026 -0.0006	-0.0031 -0.0019	-0.0035 -0.0014
315	400	-0.0007 -0.0030	0 -0.0035	0 -0.0022	-0.0007 -0.0015	-0.0003 -0.0011	-0.0011 -0.0003	-0.0016 -0.0007	-0.0018 -0.0004	-0.0022 0	-0.0024 -0.0010	-0.0029 -0.0006	-0.0034 -0.0020	-0.0039 -0.0016
400	500	-0.0008 -0.0033	0 -0.0038	0 -0.0025	-0.0008 -0.0017	-0.0003 -0.0013	-0.0013 -0.0003	-0.0018 -0.0007	-0.0020 -0.0004	-0.0025 0	-0.0026 -0.0011	-0.0031 -0.0007	-0.0037 -0.0022	-0.0043 -0.0018
500	630	-0.0009 -0.0035	0 -0.0041	0 -0.0027	-0.0009 -0.0018	-0.0003 -0.0014	-0.0014 -0.0003	-0.0019 -0.0008	-0.0022 -0.0005	-0.0027 0	-0.0029 -0.0012	-0.0034 -0.0007	-0.0041 -0.0024	-0.0046 -0.0020

to remove all looseness from the bearing. Close attention must be paid to dimensions and tolerances to secure just enough projection of the ring to remove the play, but not so much as to induce excessive pressure or binding of the balls. The bearing at the other end of the shaft must be arranged for free axial movement of the outer ring. The bearings in **Fig. 1-9** can be separated if desired with one bearing at each end of the shaft. Although this arrangement will remove the looseness from both ends of the shaft, serious stresses may be induced by a temperature difference between shaft and housing. Preloaded, double-row radial bearings are made by some manufacturers.

1.7 Unground Ball Bearings

The foregoing discussion has referred to ball bearings of the highest quality of materials and workmanship. Other bearings of lower quality can be purchased for installations requiring less accuracy or where cost is the controlling factor. The rings are made on automatic screw machines and are hardened but not ground.

Different types of construction are in use. The bearing of **Fig. 1-10(a)** has the outer ring split by a plane perpendicular to the axis. The bearing is assembled by spinning the edges of the bushing, which is slipped over the outer rings. The bearing of **Fig. 1-10(b)** has a split inner ring, and is made by staking the bore of the inner ring as shown. Various additional features, such as pulleys, gears, castor wheels, and so on, can be incorporated as an integral part of the outer ring. **Fig. 1-10 (c)** shows a sheave-idler in which the outer ring is formed by the stampings comprising the sheave. Unground ball bearings are frequently cheaper than an equivalent plain bushing.

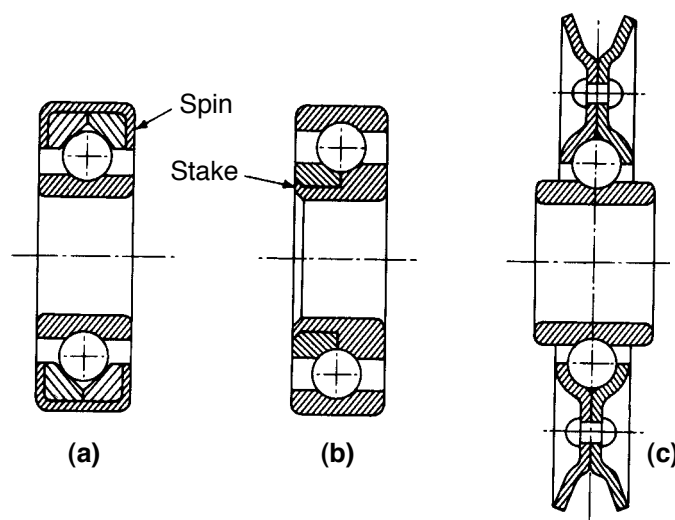

Fig. 1-10 Types of Unground Ball Bearings

1.8 Roller Bearings

Several roller bearings are shown in **Fig. 1-2** as well as in **Fig. 1-11**. These types of bearings are usually used when shock and impact loads are present, or when large bearings are needed.

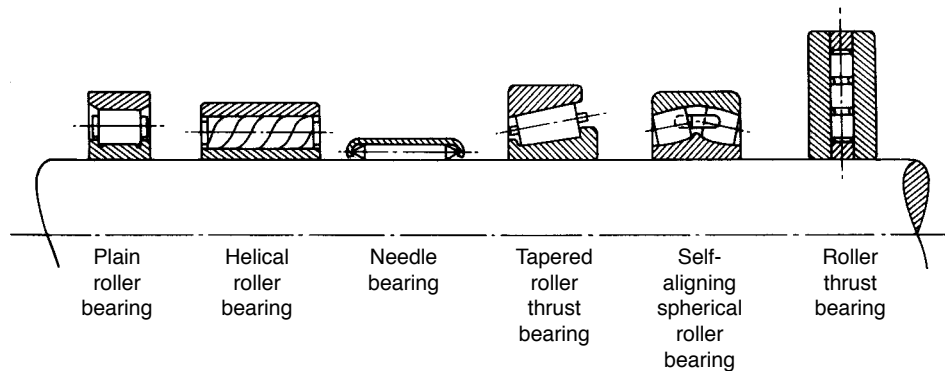

Fig. 1-11 Types of Roller Bearings

A roller bearing, in general, consists of the same four elements as a ball bearing: the two rings, the cage, and the rollers. Some typical examples of roller bearings are shown in **Fig. 1-11**. Means of mounting roller bearings are shown in **Fig. 1-12**.

In a plain roller bearing, the flanges on the rings serve to guide the rollers in the proper direction. When the flanges are omitted from one of the rings, as shown in **Fig. 1-11**, the rings can then be displaced axially with respect to each other, and no thrust component can be carried.

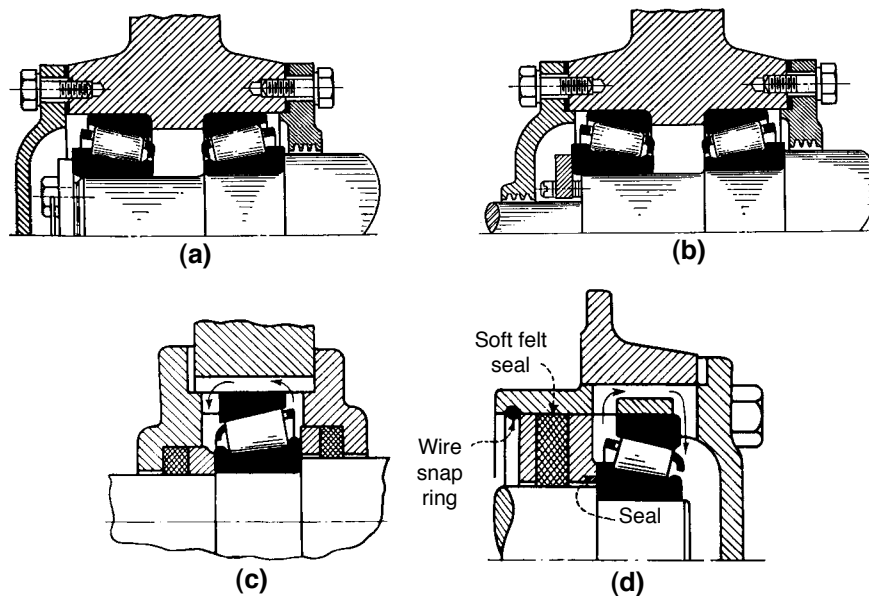

Fig. 1-12 Details of Mounting of Roller Bearings

In addition to the radial load, the tapered roller bearing can carry a large axial component whose magnitude depends on the angularity of the rollers. The radial load will also produce a thrust component. The outer ring is separable from the remainder of the bearing. In this type of

bearing, it is possible to make adjustment for the radial clearance. Two bearings are usually mounted opposed to each other, and the clearance is controlled by adjusting one bearing against the other. Double-row tapered roller bearings are also available.

Roller bearings in general can be applied only where the angular misalignment caused by shaft deflection is very slight. This deficiency is not present in the spherical roller bearing. It has excellent load capacity and can carry a thrust component in either direction.

In the helical roller bearing, the rollers are wound from strips of spring steel, and afterwards are hardened and ground to size. If desired, the rollers can bear directly on the shaft without an inner ring, particularly if the shaft surface has been locally hardened. This bearing has been successfully applied under conditions of dirty environment.

The needle bearing has rollers that are very long as compared to their diameters. Cages are frequently not used, and the inner ring may or may not be present. The outer ring may consist of hardened thin-walled metal as shown in **Fig. 1-13**; the housing in which the bearing is mounted must have sufficient thickness to give adequate support. The friction of needle bearings is several times as great as for ordinary cylindrical roller bearings. Because of the tendency of the unguided rollers to skew, needle bearings are particularly adapted to oscillating loads, as in wrist pins, rocker arms, and universal joints. For continuous rotation, needle bearings are usually suitable where the loading is intermittent and variable so that the needles will be frequently unloaded and thus tend to return to their proper locations. When the application involves angular misalignment of the shaft, two short bearings end to end usually are better than one bearing with long rollers. The needle bearing is low-priced and requires very little radial space.

Spherical roller bearings, **Figures 1-12** and **1-13**, can be used when the shaft has angular misalignment.

Thrust bearings can be constructed by the use of straight or tapered rollers.

Roller bearings are selected by a process similar to that used for ball bearings. They must be chosen, however, in accordance with the recommendations given in the catalog of the manufacturer of the particular type of bearing under consideration.

Roller bearings are usually made of case-hardened steels. The carburized case or exterior should have a hardness of 58-63 R_c. The core is softer with a hardness of 25-40 R_c. Certain plain-carbon and alloy steels have been found suitable for roller bearing service. The maximum temperature is limited to about 350° F.

The separator, cage, or retainer for conventional bearings is usually a stamping of low-carbon steel. For higher speeds or precision service, the separator is machined from a suitable copper alloy, such as bronze. Cages are also made of a solid lubricant material for use where

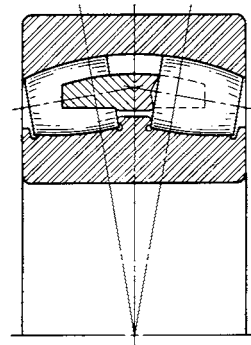

Fig. 1-13 Self-Aligning Spherical Roller Bearing for Radial and Thrust Loads

conventional types of lubrication cannot be used.

1.9 Lubrication and Surface Finishes

Rolling contact bearings have to be lubricated in addition to having exceedingly good surface finishes.

The life of a rolling element bearing depends to a large extent on the smoothness of the contacting surfaces – the balls, rollers, and races. Typical surface roughness dimensions for production bearings are as follows:

Balls	2– 3 $\mu\text{in rms}$
Ball races	6–10 $\mu\text{in rms}$
Rollers	8–12 $\mu\text{in rms}$
Roller races	10–20 $\mu\text{in rms}$

These are in terms of microinches or millionths of an inch, usually written μin .

The unit of measurement of the surface roughness is rms which stands for “root-mean-square height”. This value is obtained by drawing a diamond point instrument over the surface with a magnified readout. These measurements are taken at equidistant points on the profile, squaring these values, adding them, dividing the sum by the number of readings taken and taking the square root of this average.

There are calibrated specimens available and surface roughness can be established by comparison to the specimen.

Surface finishes of bearings vary considerably from manufacturer to manufacturer. They are usually not given specifically for each product.

As far as lubrication is concerned, in general, the application environment will usually dictate the proper lube required. Today’s lubrication selection has varied greatly over the past few years. Modern methods of mixing, compounding and blending various additives and bases has become a very exact science, a far cry from late 1940 when almost all lubricants were a refined petroleum product.

Operational conditions such as temperature, loads, speed, environment and torque available, will determine what type should be used – oil, grease or dry films. Oil fluid is the base lubricant for nearly all bearings, whereas grease is an oil that has been thickened. The use of lubrication will reduce friction and wear, prevent corrosion or oxidation and help to prevent heat buildup within the bearing. Other benefits that result from proper lubrication are quietness, lower torque and extended life. Lubrication selection is very important to good bearing performance. The following tables of lubrications shown are the most widely used by bearing users today. Due to the constant change of product demand and scientific technology, we recommend that a QBC engineer be consulted if you cannot locate a suitable lubrication in the following charts.

Unless otherwise specified by the customer, QBC will supply bearings with an oil lubrication meeting military specifications (MIL-L-6085A) or grease meeting (MIL-G-23827A).

The numbering system developed by QBC incorporates a lubrication code. This gives the user an opportunity to specify the lubricant required as per **Table 1-10**. In case the code numbers assigned do not cover the lubricant required, **Tables 1-11** thru **1-13** list the lubricants available on special orders.

Table 1-10 Available Lubricants

Lubricant Code	Brand Name	Basic Type Oil	Operating Temp. °F	Uses
01	*Windsor L245X (MIL-L-6085A)	Synthetic oil	-65 to +300	Light general purpose instrument oil
15	DuPont Krytox 143 AC	Fluorinated oil	-30 to +550	High temperature stability with good lubricity properties
49	AeroShell #7 (MIL-G-23827A)	Diester	-100 to +300	Wide temperature range; good general purpose grease
54	Texaco Low Temp EP (MIL-G-23827A)	Synthetic Ester	-65 to +250	Low torque at cold temperature
20	*Exxon Beacon 325	Synthetic grease	-65 to +250	General purpose grease
39	*Exxon Andok C	Channeling petroleum grease	-20 to +250	Smooth running, long life with minimum migration
13	Toray SH44M	Silicone grease	-25 to +350	Higher temperature stability
48	*Mobil 28 (MIL-G-81322)	Synthetic hydrocarbon	-65 to +350	Wide temperature range, good low temperature torque, general purpose
72	Multemp PS No. 2	Petroleum grease	-60 to +250	Low torque, general purpose grease
75	Chevron SRI-2	Mineral grease	-20 to +350	High speed, high load grease
83	*Shell Alvania X2	Mineral grease	-30 to +250	Long life
10	DuPont Krytox 240AC (MIL-G-27617)	Fluorinated grease	-30 to +550	High temperature stability with good lubricity properties
12	KYODO SRL	Synthetic grease	-40 to +300	Low noise and low torque applications
25	NIG-ACE W	Synthetic grease	0 to +300	Low noise and low torque applications
40	Isoflex JL 032R	Synthetic grease	-60 to +250	High speed, low torque grease
04	U-1494	Synthetic grease	-40 to +350	High speed, high load applications

*Most popular and readily available lubrication.

If no lubrication is called out, QBC will ship bearings with one of these general purpose lubricants.

Table 1-11 Oil Lubricants Available on Special Order

Manufacturer & Trade Name	Mil. Spec	Oper. Range, °F	Type	Pouring Point, °F	Flash Point, °F	Viscosity CS 75°F/210°F
Anderson Oil Co. LS252	MIL-17353A	-65/250	Diester	-75	340	7.6/1.9
Bendix Corp. P10	MIL-L-6085A	-70/350	Diester	-80	420	23.4/3.8
Bray Oil Co. NPT3A 885 NPT9	MIL-L-6085	-65/175 -50/400 -30/350	Diester Diester Ester	-90 -85 -50	400 410 495	19/3.5 1875/9 710/55
Dow Corning DC200 DC510 DC550 FS1265	VVL1078 MIL-L-27694	-40/550 -70/500 -40/450 -50/300	Silicone Silicone Silicone Silicone	-50 -80 -50 -30	600 600 600 500	Various Various 125/20 Various
DuPont, E.I. Krytox 143 AB		-45/450	Perfluor	-45	500	85/10.3
Exxon Corp. P15A Aviation Inst. Oil Univis P12 Univis P38	MIL-L-7808 MIL-L-7870 MIL-L-6085A MIL-L-6085	-65/300 -65/290 -75/300 -65/300	Diester Petroleum Diester Diester	-75 -70 -90 -70	450 300 410 415	22/3.5 17/2.6 30/3.6 72/37
General Electric Versilube F44 Versilube F50 Versilube SF81 Versilube SF96	MIL-S-81087	-100/500 -100/400 -40/400 -40/400	Silicone Silicone Silicone Silicone	-100 -100 -55 -50	550 550 600 600	70/15 75/22 Various 40/16.5
Gulf Oil Co. Synthetic Fluid#6		-50/275	Mineral	-90	295	3200/12
Houghton Oil Cosmolube 270A	MIL-L-6085A	-65/250	Diester	-70	365	15/3.5
Mobil Oil SHC824 XRL743A		-50/350 -50/350	Synthetic Synthetic	-65 -65	455 520	100/6.5 100/6.5
MPS Corp. MO119		-30/250	Synthetic	-80	455	119 @ 100°F
Shell Oil Co. Aeroshell #3 Aeroshell #12 Aeroshell #4	MIL-L-7870 MIL-L-6085A MIL-H-5606	-70/240 -70/300 -70/500	Petroleum Diester Petroleum	-75 -70 -85	275 365 215	16.5/2.3 21.5/3.5 859/10.4
Tenneco Chemical Anderol L401D Anderol L423	MIL-L-6085A	-75/260 -80/350	Diester Synthetic	-80 -100	430 370	19.7/3.4 200/5.1

Table 1-12 Greases Available on Special Order

Manufacturer & Trade Name	Mil. Spec	Oper. Range, °F	Base Oil	Thickener	Color
American Oil Co.					
Rykon Premium #2		-10/200	Mineral	Arylurea	Reddish
Rykon Premium #3		-20/250	Mineral	Arylurea	Pink
Supermil ASU31052	MIL-G-25013	-100/450	Silicone	Arylurea	Lavender
Supermil ASU72832	MIL-G-23827A	-100/250	Diester	Lithium	Amber
Bray Oil Co.					
Braycote 627S	MIL-G-23827	-100/300	Ester	Organic	Lt. Brown
Braycote 637S	MIL-G-25537	-65/260	Mineral	Calcium Soap	Lt. Brown
601		-100/390	Polyether	Tetrafluor	Off White
Chevron Oil Co.					
BRB-2	MIL-G-3545C	-20/350	Mineral	Polyurea	Blue Green
OHT		+20/300	Mineral	Sodium	Greenish
NRR335		-65/300	Synthetic Aeromatic	Sodium	Maroon
Dow Corning					
Molykote BR2 Plus		-20/300	Mineral	Lithium	Black
Molykote 33		-100/350	Silicone	Lithium	Gray
Molykote 41		-0/550	Silicone	Lithium	Black
Molykote 44	MIL-G-46886A	-100/400	Silicone	Lithium	Dark Amber
Molykote 55M	MIL-G-4343	-65/350	Silicone	Lithium	Tan
DuPont, E.I.					
Krytox 240AA	MIL-G-27617	-30/450	Fluor Carbon	Vidax	White
Krytox 240AB	MIL-G-27617	-30/450	Fluor Carbon	Vidax	White
Krytox 240AZ	MIL-G-27617	-65/300	Fluor Carbon	Vidax	White
Krytox 240AC	MIL-G-27617	-30/550	Perfluor	Tetrafluor	White
Exxon Corp.					
Andok B	MIL-G-18709A	-20/250	Mineral	Sodium	Brown
Andok 260	MIL-G-3545C	-20/250	Mineral	Sodium	Amber
General Electric					
Versilube G351	MIL-L-15719A	-40/400	Silicone	Lithium	Cream
Houghton E.F.					
Cosmolube 615	MIL-L-4343	-65/375	Silicone	Lithium	Lt. Brown
Kyodo Yushi					
PS #2		-60/230	Diester	Lithium	White
Mobil Oil					
BRB #23	MIL-L-7711	-0/250	Petroleum	Sodium	Tan
Mobil 24	MIL-G-25013	-100/550	Silicone	Organic	Reddish
Mobil 27	MIL-G-23827	-65/325	Carbon	Non Soap	Tan

Table 1-13 Greases Available on Special Order

Manufacturer & Trade Name	Mil. Spec	Oper. Range, °F	Base Oil	Thickener	Color
NYE Rheolube					
703A		-30/250	Mineral	Sodium	Tan
716B		-60/300	Polyol Ester	Lithium	Tan
781D		-95/390	Silicone	Lithium	Off White
899RP		-130/480	Fluorether	PTFE	White
2000		-60/260	Hydrocarbon	Organic	Red
Rheo Temp 500	MIL-G-3278A	-65/350	Diester	Sodium	Blue
Shell Oil					
Aeroshell #5	MIL-G-3545C	-20/300	Petroleum	Microgel	Dark Brown
Aeroshell #6	MIL-G-24139	-40/250	Mineral	Microgel	Amber
Aeroshell #7	MIL-G-23827A	-100/300	Diester	Microgel	Amber
Aeroshell #14	MIL-G-23827	-65/250	Mineral	Calcium Soap	Tan
Aeroshell #17	MIL-G-21164	-100/300	Diester	Microgel	Dark Grey
Aeroshell #22	MIL-G-81322A	-80/350	Diester	Microgel	Dark Grey
Alvania #3	MIL-G-81322C	-30/275	Mineral	Lithium	Amber
Cyprina #3	MIL-G-18709	-0/250	Mineral	Lithium	Lt. Tan
Dolium R #2		-30/300	Mineral	Ashless	Amber
Darina	MIL-G-18709	-0/300	Mineral	Microgel	Amber
Royal Lubricant					
Royco 13D	MIL-G-25013	-100/450	Silicone	PTFE	Lavender
Royco 21	MIL-G-7421	-100/250	Diester	Lithium	Brownish
Royco 22MS	MIL-G-81827	-80/360	Diester	Clay	Black
Royco 27A	MIL-G-23827	-100/300	Diester	Lithium	Brownish
Royco 37	MIL-G-25537	-65/250	Mineral	Calcium Soap	Tan
Royco 64C	MIL-G-21164	-65/250	Diester	Lithium	Black
Tenneco Chem. (Huls)					
Anderol 753A		-40/300	Diester	Lithium	Lt. Brown
Anderol 757		-40/300	Diester	Lithium	Lt. Brown
Anderol 761		-40/400	Diester	Silica	Lt. Brown
Anderol 793A	MIL-G-3278A	-65/300	Diester	Lithium	Lt. Amber
Anderol 794		-65/250	Diester	Lithium	Lt. Amber
Anderol 795		-65/300	Diester	Lithium	Off White
Texaco Oil Co.					
Premium RB		-30/325	Mineral Syn-	Lithium	Orange
Low Temp EP	MIL-G-23827	-65/250	thetic Mineral	Lithium	Purplish Brown
Regal AFB #2	MIL-G-18709	-40/250	Parafin	Lithium	Green
Unitemp 500	MIL-G-3278A	-65/350	Diester	Sodium	Blue