

RECIRCULATING LINEAR BALL BEARINGS "RK" and "RKD"

The recirculating linear ball bearings type "RK" are mainly composed of three parts. The former is a central body in coro hardened steel (hardness HRC 60 ± 2) whose purpose is to hold the charge. The balls are conveyed to the V-shaped rolling track of the rail, suitably kept by a polyamide block as to hold and give them the direction.

The recirculating linear ball bearings "RK", once coupled with rails "GR" or "GRD", allow linear movements limited only by the length of the rails themselves.

It is important to mention the possibility to use on the same way, several units with independent motion.

Max. admitted speed: 120 m/min.

Max. admitted acceleration: 50 m/sec²

The recirculating linear ball bearings "RK" (size 6 ÷ 9) can be supplied with damping elements (RKD) to reduce the noisiness. This reduce however the load capacity.



Recirculating linear ball bearings "RK" and "RKD"

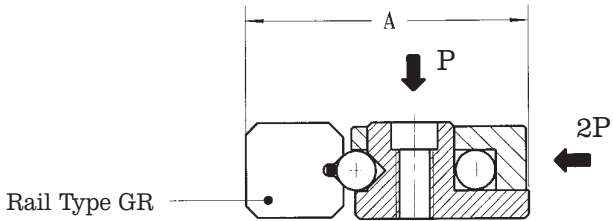
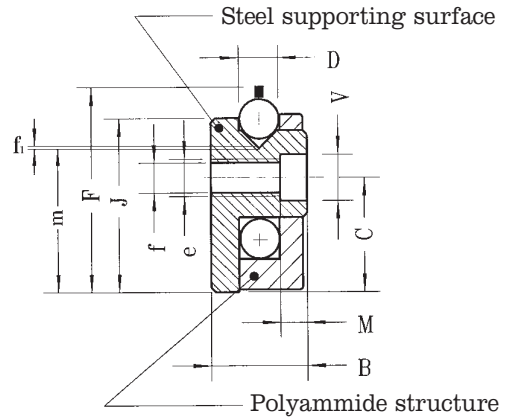
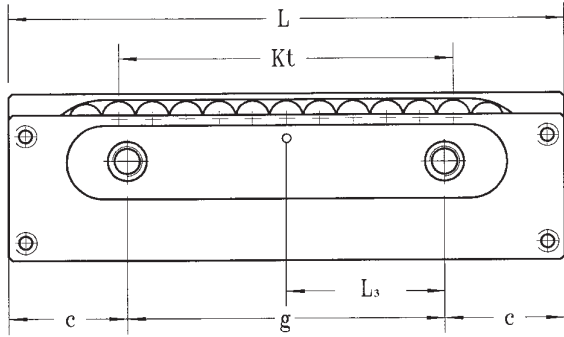

Ball bearings type	RK3075	RK6100	RKD6100	RK6150	RKD6150	RK9150	RKD9150	RK9200	RKD9200
L	75	100	100	150	150	150	150	200	200
B	8	15	15	15	15	22	22	22	22
F	16,9	29	29	29	29	45,2	45,2	45,2	45,2
g	25	50	50	2x50	2x50	100	100	100	100
c	25	25	25	25	25	25	25	50	50
J	14,7	25,7	25,7	25,7	25,7	38,7	38,7	38,7	38,7
C	9	15	15	15	15	26	26	26	26
e	M4	M6	M6	M6	M6	M8	M8	M8	M8
f	3,3	5,2	5,2	5,2	5,2	6,8	6,8	6,8	6,8
V	6	9,5	9,5	9,5	9,5	10,5	10,5	10,5	10,5
M	3,2	5,2	5,2	5,2	5,2	6,2	6,2	6,2	6,2
D	3	6	6	6	6	9	9	9	9
Kt	48	60	60	102	102	90	90	144	144
Max. allowable Load (N)	425	715	650	1170	1100	1650	1500	2550	2400
A	23,5	40	40	40	40	61	61	61	61
L₃	12,5	25	25	25	25	50	50	50	50
m	11,5	19,7	19,7	19,7	19,7	32,4	32,4	32,4	32,4
f₁	Ø 1,5	Ø 2	Ø 2	Ø 2	Ø 2	Ø 3	Ø 3	Ø 3	Ø 3