

Applications of rails of different length with protruding cages

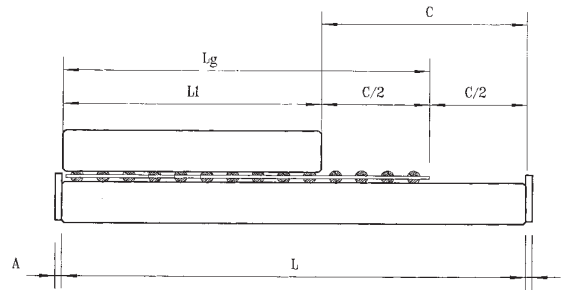
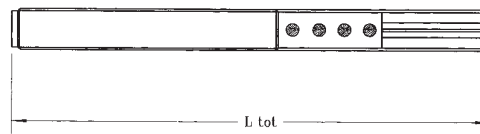

Fig. 9



If, for example, we intend to build a small carrier (200 mm long) which rides on a structure 800 mm long for a stroke of 600 mm, assuming the loads to be of limited magnitude, we could select the following material:

- 2 rails - GR9 800
- 2 rails - GR9 200 with chamfers
- 2 Cages - BB9 with 27 rollers
- 4 end pieces - GC9

In this case the selection was based on the longer rail, thus

$$L_g = L - C/2 = 800 - 300 = 500 \text{ mm}$$

$$N_R = L_g/t = 500/18 = 27.7 \text{ (thus 27 rollers)}$$

We will need also the chamfering of the rails GR9 200 to maintain the smoothness of travel of the table. The load carrying capacity will be based on the number of rollers within the two rails.

$$N_R = L_r/t = 200/18 = 11.1 \text{ (thus 11 rollers)}$$

Since the load rating is 1300N/roller, the load rating will be:

$$P = 11 \times 1300 = 14300\text{N}$$

For application similar to the one described above, it is recommended to provide guiding grooves to eliminate the potential cage swerving during motion. (See Fig. 10 and table on Page 20) (only for GR rails).

In the above-mentioned application type, the type GC end plates without wiper shall be assembled at the end of the long rail.

Similar application can be realized with rails RM + RV or GR + T.

Note: The shorter rails should always be chamfered (Additional operation performed at plant).

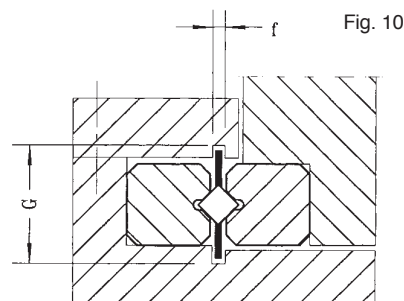

Fig. 10