

Super Ball Bushing™ Pillow Blocks (Closed Type) for End-Supported Applications

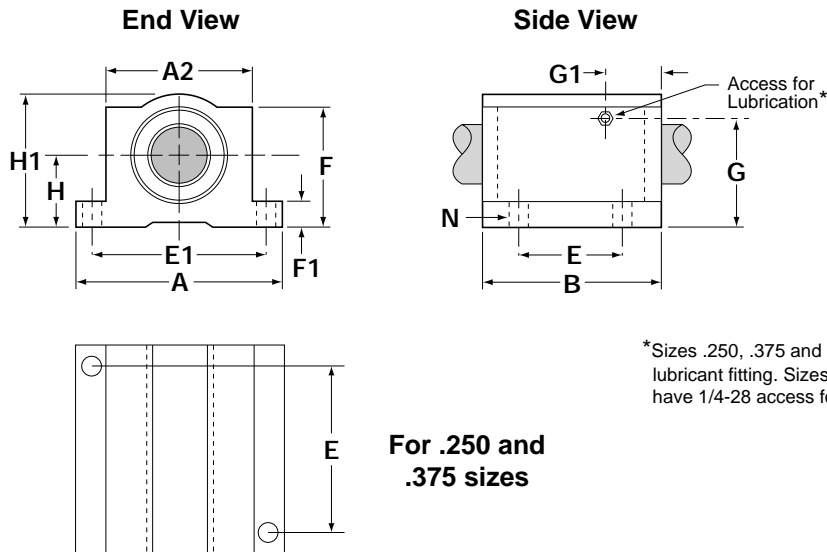

For .250 and .375 sizes

Super Ball Bushing™ Pillow Blocks (Closed Type, seal at both ends) (Dimensions in inches)								
Catalog Number	Nominal Diameter	A	A2	B	E ±.010	E1 ±.010	F	F1
TSPB-4	.250	1.63	1.00	1.19	.750	1.313	.75	.19
TSPB-6	.375	1.75	1.13	1.31	.875	1.438	.88	.19
TSPB-8	.500	2.00	1.38	1.69	1.000	1.688	1.13	.25
TSPB-10	.625	2.50	1.75	1.94	1.125	2.125	1.44	.28
TSPB-12	.750	2.75	1.88	2.06	1.250	2.375	1.56	.31
TSPB-16	1.000	3.25	2.38	2.81	1.750	2.875	1.94	.38
TSPB-20	1.250	4.00	3.00	3.63	2.000	3.500	2.50	.44
TSPB-24	1.500	4.75	3.50	4.00	2.500	4.125	2.88	.50
TSPB-32	2.000	6.00	4.50	5.00	3.250	5.250	3.63	.63

Catalog Number	G	G1	H ±.003	H1	N		Pillow Block Mass lb	Dynamic ^Δ Load Capacity lbf
					Hole	Bolt		
TSPB-4	.61	.22	.437	.81	.16	#6	.10	60
TSPB-6	.72	.22	.500	.94	.16	#6	.13	100
TSPB-8	.69	.84	.687	1.25	.16	#6	.20	255
TSPB-10	.70	.68	.875	1.63	.19	#8	.50	450
TSPB-12	.94	.72	.937	1.75	.19	#8	.60	600
TSPB-16	1.20	.86	1.187	2.19	.22	#10	1.20	1050
TSPB-20	1.50	1.20	1.500	2.81	.22	#10	2.50	1500
TSPB-24	1.75	1.25	1.750	3.25	.28	1/4	3.80	2000
TSPB-32	2.12	1.58	2.125	4.06	.41	3/8	7.00	3000

Δ See the chart on the bottom half of the next page.

Continued on the next page

NOTE: Catalog number is for a standard item.
For other options, add: **CR** Corrosion-Resistant, or **NB** Nylon Balls to end of catalog number.



Super Ball Bushing™ Pillow Blocks (Closed Type) for End-Supported Applications

Load/Life Graph (Lines indicate limiting load for given BALL BUSHING Pillow Block)

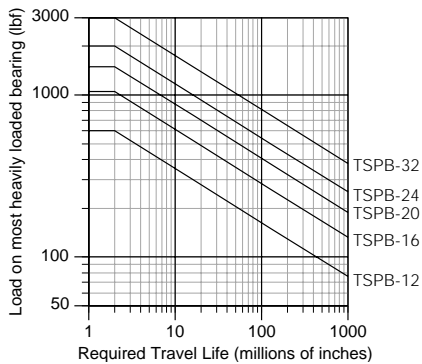
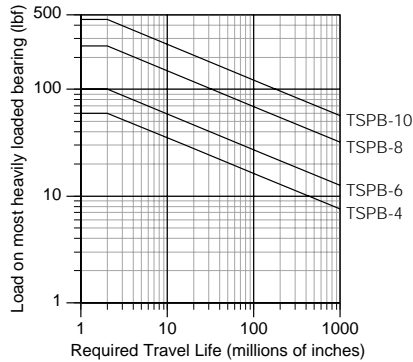

Determining BALL BUSHING Bearing Size

To determine the proper BALL BUSHING bearing size, enter the chart with the maximum load of the most heavily loaded bearing and the required travel life. Mark where the two lines intersect. All BALL BUSHING bearing sizes that pass through or above and to the right of this point may be suitable for this application.

Note: For the purpose of using this chart:

$$\text{Load on Most Heavily Loaded Bearing} = \frac{\text{Maximum Applied Load}}{K_0}$$

where:

K_0 = the Load Correction Factor, which can be determined from the Polar Graph below.

Dynamic Load Capacity Correction Factor, K_0

The Dynamic Load Capacity is based on a rated travel life of 2 million inches. The actual Dynamic Load Capacity can be affected by the orientation of the bearing or the direction of the applied load. For dynamic load Correction Factors, see polar graphs below.

Polar Graphs

The actual Dynamic Load Capacity of a BALL BUSHING bearing is determined by the orientation of the bearing or direction of the applied load. The load Correction Factor K_0 is found by knowing the direction of the applied load relative to the orientation of the bearing's ball tracks and referring to the polar graph. To determine the actual Dynamic Load Capacity, multiply the proper Correction Factor by the Dynamic Load Capacity listed in the product table on the previous page.

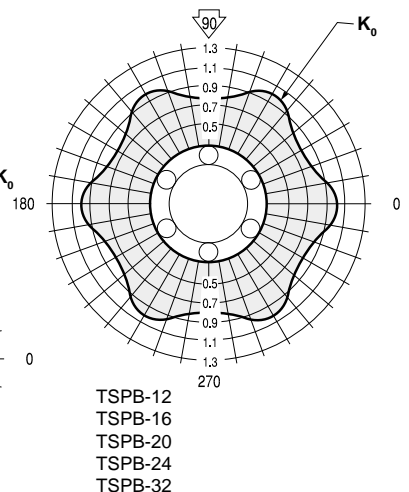
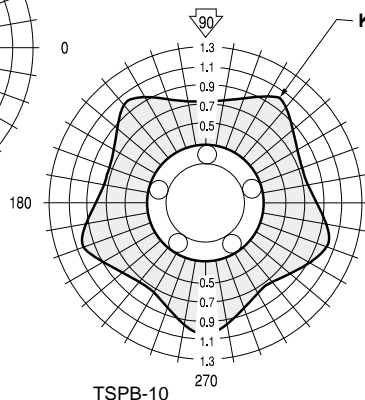
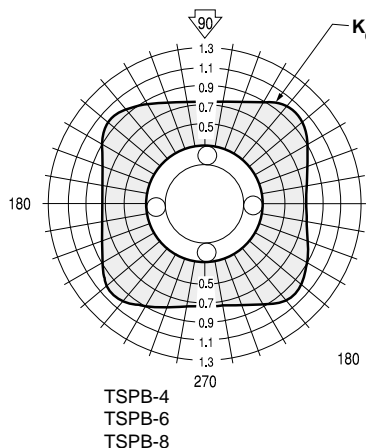

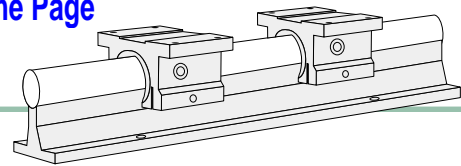

Super Ball Bushing™ Pillow Blocks

(Open Type) for Continuously-Supported Applications

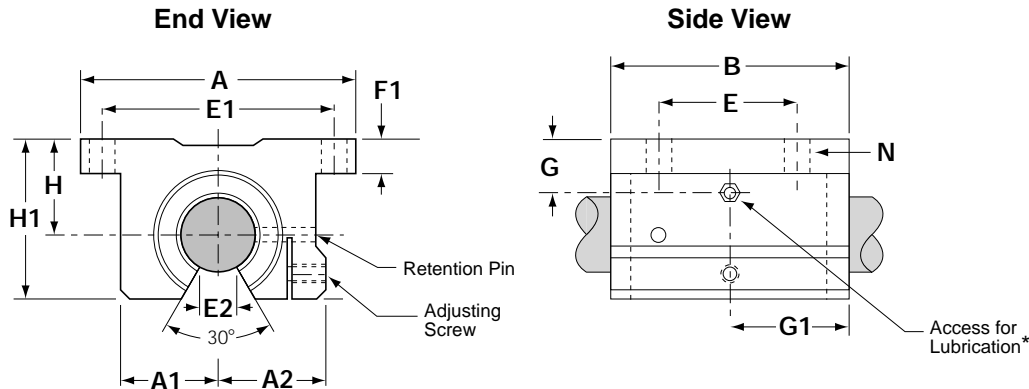

*Size .500 has oil lubricant fitting. Sizes .625 and above have 1/4-28 access for lubrication.

Super Ball Bushing™ Pillow Blocks (Open Type, seal at both ends)									
(Dimensions in inches)									
Catalog Number	Nominal Diameter	A	A1	A2	B	E ±.010	E1 ±.010	E2 Min.	F1
TSPB-8-OPN	.500	2.00	.69	.75	1.50	1.000	1.688	.31	.25
TSPB-10-OPN	.625	2.50	.88	.94	1.75	1.125	2.125	.37	.28
TSPB-12-OPN	.750	2.75	.94	1.00	1.88	1.250	2.375	.43	.31
TSPB-16-OPN	1.000	3.25	1.19	1.25	2.63	1.750	2.875	.56	.38
TSPB-20-OPN	1.250	4.00	1.50	1.63	3.38	2.000	3.500	.62	.44
TSPB-24-OPN	1.500	4.75	1.75	1.88	3.75	2.500	4.125	.75	.50
TSPB-32-OPN	2.000	6.00	2.25	2.44	4.75	3.250	5.250	1.00	.63

Catalog Number	G	G1	H ±.003	H1	N		Pillow Block Mass lb	Dynamic ^Δ Load Capacity lbf
					Hole	Bolt		
TSPB-8-OPN	.69	.75	.687	1.13	.16	#6	.2	230
TSPB-10-OPN	.42	.53	.875	1.44	.19	#8	.4	320
TSPB-12-OPN	1.08	.55	.937	1.56	.19	#8	.5	470
TSPB-16-OPN	1.37	.76	1.187	2.00	.22	#10	1.0	780
TSPB-20-OPN	1.73	1.05	1.500	2.56	.22	#10	2.1	1170
TSPB-24-OPN	2.03	1.12	1.750	2.94	.28	.25	3.2	1560
TSPB-32-OPN	2.50	1.44	2.125	3.63	.41	.38	6.0	2350

Δ See the chart on the bottom half of the next page.

Continued on the next page

NOTE: Catalog number is for a standard item.
For other options, add: **CR** Corrosion-Resistant or **NB** Nylon Balls to end of catalog number.



Super Ball Bushing™ Pillow Blocks

(Open Type) for Continuously-Supported Applications

Load/Life Graph (Lines indicate limiting load for given BALL BUSHING Pillow Block)

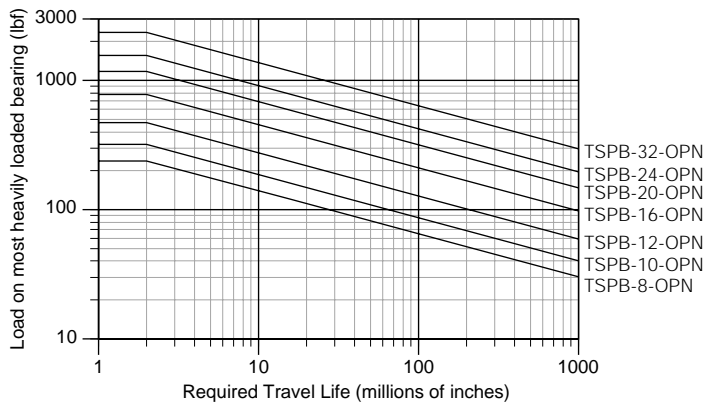

Determining BALL BUSHING Bearing Size

To determine the proper BALL BUSHING bearing size, enter the chart with the maximum load of the most heavily loaded bearing and the required travel life. Mark where the two lines intersect. All BALL BUSHING bearing sizes that pass through or above and to the right of this point may be suitable for this application.

Note: For the purpose of using this chart:

$$\text{Load on Most Heavily Loaded Bearing} = \frac{\text{Maximum Applied Load}}{K_0}$$

where:

K_0 = the Load Correction Factor, which can be determined from the Polar Graph below.

Dynamic Load Capacity Correction Factor, K_0

The Dynamic Load Capacity is based on a rated travel life of 2 million inches. The actual Dynamic Load Capacity can be affected by the orientation of the bearing or the direction of the applied load. For dynamic load Correction Factors, see polar graphs below.

Polar Graphs

The actual Dynamic Load Capacity of a BALL BUSHING bearing is determined by the orientation of the bearing or direction of the applied load. The load Correction Factor K_0 is found by knowing the direction of the applied load relative to the orientation of the bearing's ball tracks and referring to the polar graph. To determine the actual Dynamic Load Capacity, multiply the proper Correction Factor by the Dynamic Load Capacity listed in the product table on the previous page.

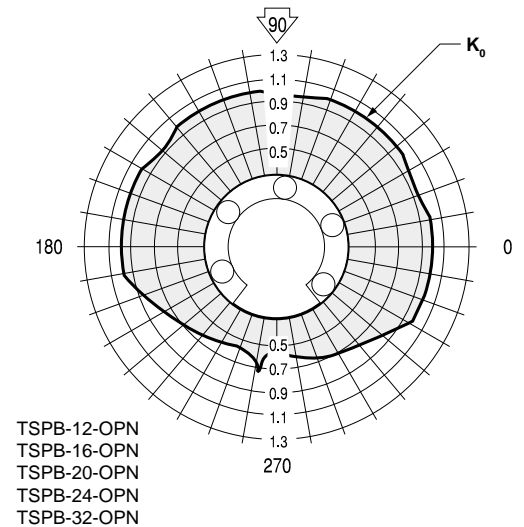
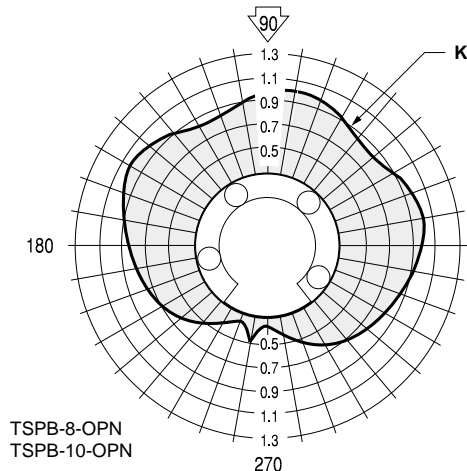

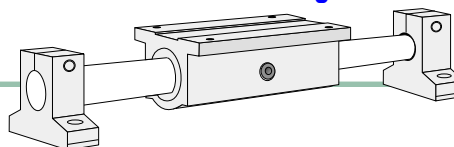

Super Ball Bushing™ Twin Pillow Blocks

(Closed Type) for End-Supported Applications

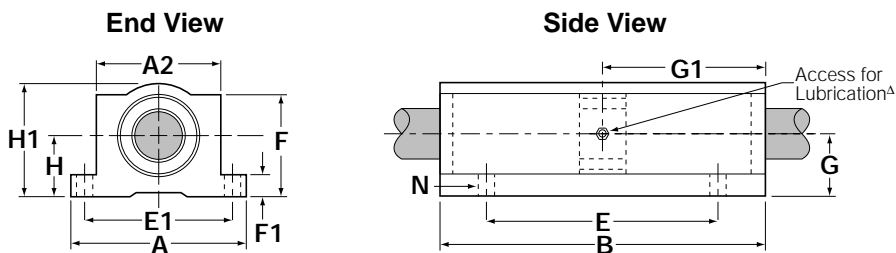

^ΔSizes .250, .375 and .500 have oil lubricant fitting.
 Sizes .625 and above have 1/4-28 access for lubrication.

Super Ball Bushing Twin Pillow Blocks (Closed Type, seal at both ends)								
(Dimensions in inches)								
Catalog Number	Nominal Diameter	A	A2	B	E ± .010	E1 ± .010	F	F1
TTWN-4	.250	1.63	1.00	2.50	2.000	1.313	.75	.19
TTWN-6	.375	1.75	1.13	2.75	2.250	1.438	.88	.19
TTWN-8	.500	2.00	1.38	3.50	2.500	1.688	1.13	.25
TTWN-10	.625	2.50	1.75	4.00	3.000	2.125	1.44	.28
TTWN-12	.750	2.75	1.88	4.50	3.500	2.375	1.56	.31
TTWN-16	1.000	3.25	2.38	6.00	4.500	2.875	1.94	.38
TTWN-20	1.250	4.00	3.00	7.50	5.500	3.500	2.50	.44
TTWN-24	1.500	4.75	3.50	9.00	6.500	4.125	2.88	.50

Catalog Number	G	G1	H ± .003	H1	N		Pillow Block Mass lb	Dynamic* Load Capacity lbf
					Hole	Bolt		
TTWN-4	.44	1.25	.437	.81	.16	#6	.19	120
TTWN-6	.50	1.37	.500	.94	.16	#6	.25	200
TTWN-8	.59	1.75	.687	1.25	.16	#6	.40	510
TTWN-10	.85	2.00	.875	1.63	.19	#8	1.00	900
TTWN-12	.94	2.25	.937	1.75	.19	#8	1.20	1200
TTWN-16	1.19	3.00	1.187	2.19	.22	#10	2.40	2100
TTWN-20	1.50	3.75	1.500	2.81	.22	#10	5.00	3000
TTWN-24	1.75	4.50	1.750	3.25	.28	1/4	7.80	4000

*See the chart on the bottom half of the next page.

Continued on the next page

NOTE: Catalog number is for a standard item.
 For other options, add: **CR** Corrosion-Resistant or **NB** Nylon Balls to end of catalog number.



Super Ball Bushing™ Twin Pillow Blocks (Closed Type) for End-Supported Applications

Load/Life Graph (Lines indicate limiting load for given BALL BUSHING Pillow Block)

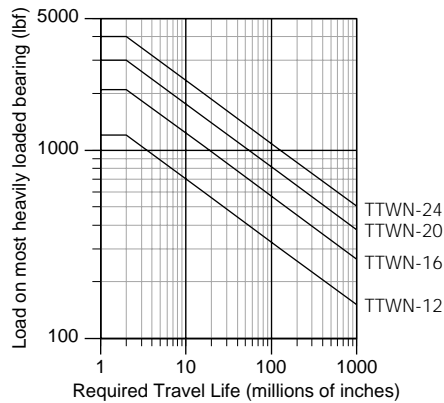
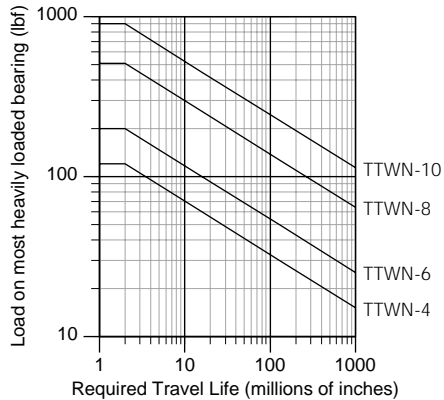

Determining BALL BUSHING Bearing Size

To determine the proper BALL BUSHING bearing size, enter the chart with the maximum load of the most heavily loaded bearing and the required travel life. Mark where the two lines intersect. All BALL BUSHING bearing sizes that pass through or above and to the right of this point may be suitable for this application.

Note: For the purpose of using this chart:

$$\text{Load on Most Heavily Loaded Bearing} = \frac{\text{Maximum Applied Load}}{K_0}$$

where:

K_0 = the Load Correction Factor, which can be determined from the Polar Graph below.

Dynamic Load Capacity Correction Factor, K_0

The Dynamic Load Capacity is based on a rated travel life of 2 million inches. The actual Dynamic Load Capacity can be affected by the orientation of the bearing or the direction of the applied load. For dynamic load Correction Factors, see polar graphs below. Dynamic Load Capacity of Super BALL BUSHING Twin Pillow Blocks is based on two bearings equally loaded.

Polar Graphs

The actual Dynamic Load Capacity of a BALL BUSHING bearing is determined by the orientation of the bearing or direction of the applied load. The load Correction Factor K_0 is found by knowing the direction of the applied load relative to the orientation of the bearing's ball tracks and referring to the polar graph. To determine the actual Dynamic Load Capacity, multiply the proper Correction Factor by the Dynamic Load Capacity listed in the product table on the previous page.

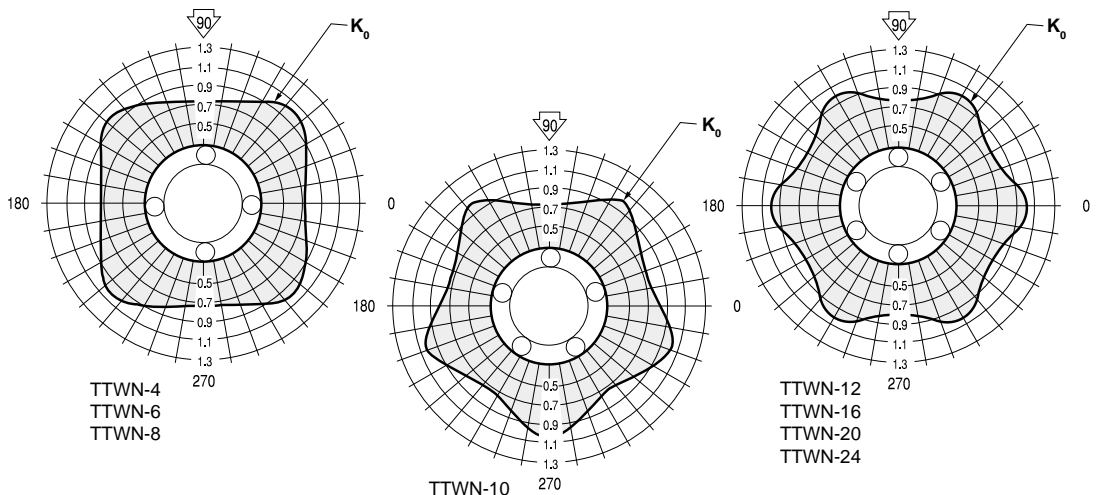

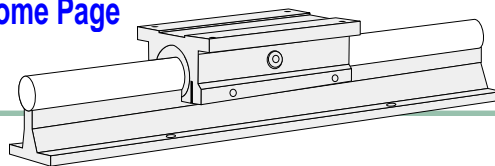

Super Ball Bushing™ Twin Pillow Blocks

(Open Type) for Continuously-Supported Applications

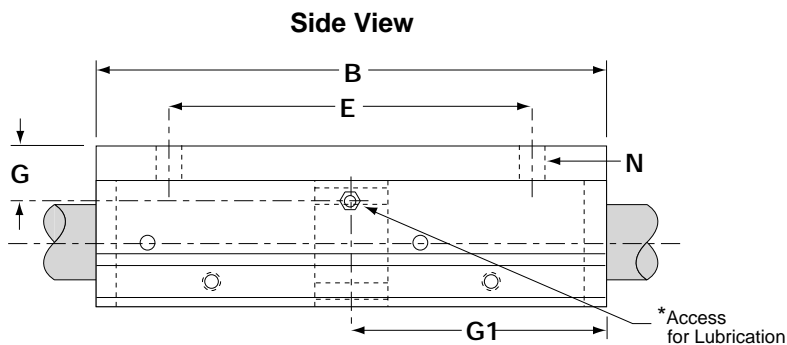
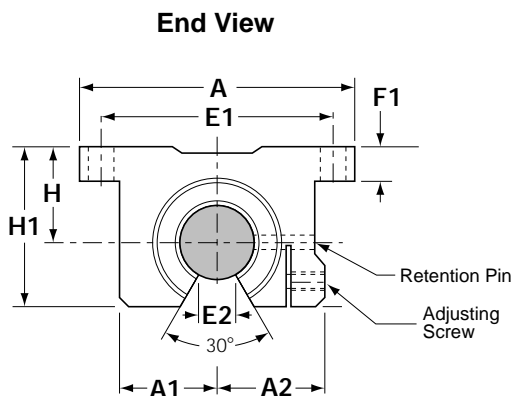

*Size .500 has oil lubricant fitting. Sizes .625 and above have 1/4-28 access for lubrication.

Super Ball Bushing™ Twin Pillow Blocks (Open Type, seal at both ends)
(Dimensions in inches)

Catalog Number	Nominal Diameter	A	A1	A2	B	E ±.010	E1 ±.010	E2 Min.	F1
TTWN-8-OPN	.500	2.00	.69	.75	3.50	2.500	1.688	.31	.25
TTWN-10-OPN	.625	2.50	.88	.94	4.00	3.000	2.125	.37	.28
TTWN-12-OPN	.750	2.75	.94	1.00	4.50	3.500	2.375	.43	.31
TTWN-16-OPN	1.000	3.25	1.19	1.25	6.00	4.500	2.875	.56	.38
TTWN-20-OPN	1.250	4.00	1.50	1.63	7.50	5.500	3.500	.62	.44
TTWN-24-OPN	1.500	4.75	1.75	1.88	9.00	6.500	4.125	.75	.50

Catalog Number	G	G1	H ±.003	H1	N		Pillow Block Mass lb	Dynamic ^Δ Load Capacity lbf
					Hole	Bolt		
TTWN-8-OPN	.56	1.75	.687	1.13	.16	#6	.4	460
TTWN-10-OPN	.67	2.00	.875	1.44	.19	#8	.8	640
TTWN-12-OPN	.94	2.25	.937	1.56	.19	#8	1.0	940
TTWN-16-OPN	1.20	3.00	1.187	2.00	.22	#10	2.0	1560
TTWN-20-OPN	1.50	3.75	1.500	2.56	.22	#10	4.2	2340
TTWN-24-OPN	1.75	4.50	1.750	2.94	.28	.25	6.7	3120

Δ See the chart on the bottom half of the next page.

Continued on the next page

NOTE: Catalog number is for a standard item.
For other options, add: **CR** Corrosion-Resistant or **NB** Nylon Balls to end of catalog number.



Super Ball Bushing™ Twin Pillow Blocks (Open Type) for Continuously-Supported Applications

Load/Life Graph (Lines indicate limiting load for given BALL BUSHING Pillow Block)

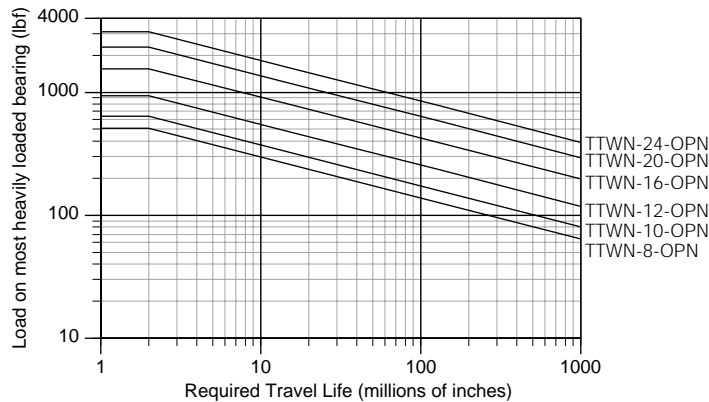

Determining BALL BUSHING Bearing Size

To determine the proper BALL BUSHING bearing size, enter the chart with the maximum load of the most heavily loaded bearing and the required travel life. Mark where the two lines intersect. All BALL BUSHING bearing sizes that pass through or above and to the right of this point may be suitable for this application.

Note: For the purpose of using this chart:

$$\text{Load on Most Heavily Loaded Bearing} = \frac{\text{Maximum Applied Load}}{K_0}$$

where:

K_0 = the Load Correction Factor, which can be determined from the Polar Graph below.

Dynamic Load Capacity Correction Factor, K_0

The Dynamic Load Capacity is based on a rated travel life of 2 million inches. The actual Dynamic Load Capacity can be affected by the orientation of the bearing or the direction of the applied load. For dynamic load Correction Factors, see polar graphs below.

Polar Graphs

The actual Dynamic Load Capacity of a BALL BUSHING bearing is determined by the orientation of the bearing or direction of the applied load. The load Correction Factor K_0 is found by knowing the direction of the applied load relative to the orientation of the bearing's ball tracks and referring to the polar graph. To determine the actual Dynamic Load Capacity, multiply the proper Correction Factor by the Dynamic Load Capacity listed in the product table on the previous page.

