

Precision Steel Ball Bushing™ Bearings (Closed Type) for End-Supported Applications

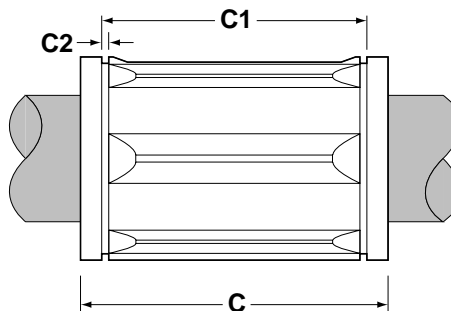
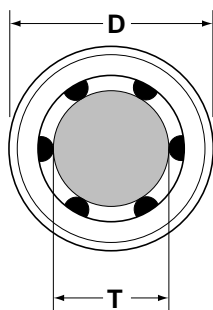

Precision Steel Ball Bushing™ Bearings (Closed Type) (Dimensions in inches)						
Catalog Number	Nominal Diameter	Length C	Distance Between Retaining Grooves C1	Ret. Ring Groove Min. C2	No. of Ball Circ.	D
TA-4812	.250	.750/.735	.515/.499	.039	3	.5000/.4996
TA-61014	.375	.875/.860	.640/.624	.039	4	.6250/.6246
TA-81420	.500	1.250/1.235	.967/.951	.046	4	.8750/.8746
TA-101824	.625	1.500/1.485	1.108/1.092	.056	4	1.1250/1.1246
TA-122026	.750	1.625/1.610	1.170/1.154	.056	5	1.2500/1.2496
TA-162536	1.000	2.250/2.235	1.759/1.741	.068	5	1.5625/1.5621
TA-203242	1.250	2.625/2.605	2.009/1.991	.068	6	2.0000/1.9995
TA-243848	1.500	3.000/2.980	2.415/2.397	.086	6	2.3750/2.3745
TA-324864	2.000	4.000/3.980	3.195/3.177	.103	6	3.0000/2.9994
TA-406080	2.500	5.000/4.975	3.978/3.958	.120	6	3.7500/3.7492
TA-487296	3.000	6.000/5.970	4.728/4.708	.120	6	4.5000/4.4990
TA-6496128	4.000	8.000/7.960	6.265/6.235	.139	6	6.0000/5.9988

Catalog Number	Working Bore Diameter T	Recommended Housing Bore		Precision Steel Ball Bushing Bearing/LinearRace Fit Up*	Precision Steel Ball Bushing Bearing Mass lb	Dynamic ^Δ Load Capacity lbf
		Normal Fit	Press Fit			
TA-4812	.2500/.2495	.5005/.5000	.4995/.4990	.0015C/.0005C	.02	19
TA-61014	.3750/.3745	.6255/.6250	.6245/.6240	.0015C/.0005C	.06	37
TA-81420	.5000/.4995	.8755/.8750	.8745/.8740	.0015C/.0005C	.08	85
TA-101824	.6250/.6245	1.1255/1.1250	1.1245/1.1240	.0015C/.0005C	.16	150
TA-122026	.7500/.7495	1.2505/1.2500	1.2495/1.2490	.0015C/.0005C	.21	200
TA-162536	1.0000/.9995	1.5630/1.5625	1.5620/1.5615	.0015C/.0005C	.38	350
TA-203242	1.2500/1.2494	2.0010/2.0000	1.9993/1.9983	.0015C/.0004C	1.10	520
TA-243848	1.5000/1.4994	2.3760/2.3750	2.3743/2.3733	.0016C/.0005C	1.43	770
TA-324864	2.0000/1.9992	3.0010/3.0000	2.9992/2.9982	.0020C/.0005C	2.75	1100
TA-406080	2.5000/2.4990	3.7510/3.7500		.0023C/.0005C	5.50	1800
TA-487296	3.0000/2.9988	4.5010/4.5000	Not Normally Recommended	.0026C/.0005C	9.50	2600
TA-6496128	4.0000/3.9980	6.0010/6.0000		.0036C/.0004C	20.20	5000

*P=Preload, C=Clearance

Continued on the next page

Δ See the chart on the bottom half of the next page.

NOTE: Catalog number is for a standard item.
For other options, add: **DD** With Integral Wipers (.500 thru 1.500), **NB** Nylon Balls, **DP** Dry-Packed, or **SS** Stainless Steel (up to 1.000 only), to end of catalog number.



Precision Steel Ball Bushing™ Bearings (Closed Type) for End-Supported Applications

Load/Life Graph (Lines indicate limiting load for given BALL BUSHING Bearing)

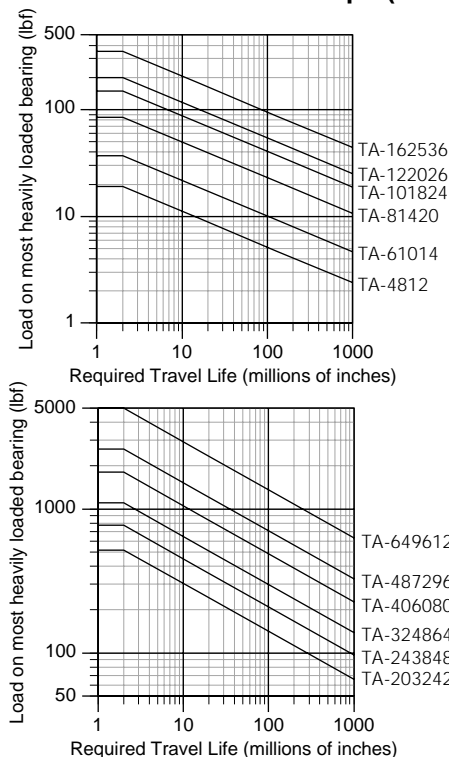

Determining BALL BUSHING Bearing Size

To determine the proper BALL BUSHING bearing size, enter the chart with the maximum load of the most heavily loaded bearing and the required travel life. Mark where the two lines intersect. All BALL BUSHING bearing sizes that pass through or above and to the right of this point may be suitable for this application.

Note: For the purpose of using this chart:

$$\text{Load on Most Heavily Loaded Bearing} = \frac{\text{Maximum Applied Load}}{K_0}$$

where:

K_0 = the Load Correction Factor, which can be determined from the Polar Graph below.

Dynamic Load Capacity Correction Factor, K_0

The Dynamic Load Capacity is based on a rated travel life of 2 million inches. The actual Dynamic Load Capacity can be affected by the orientation of the bearing or the direction of the applied load. For dynamic load Correction Factors, see polar graphs below.

NOTE: Dynamic load ratings are reduced by 30% when using stainless steel Ball Bushing bearings.

Polar Graphs

The actual Dynamic Load Capacity of a BALL BUSHING bearing is determined by the orientation of the bearing or direction of the applied load. The load Correction Factor K_0 is found by knowing the direction of the applied load relative to the orientation of the bearing's ball tracks and referring to the polar graph. To determine the actual Dynamic Load Capacity, multiply the proper Correction Factor by the Dynamic Load Capacity listed in the product table on the previous page.

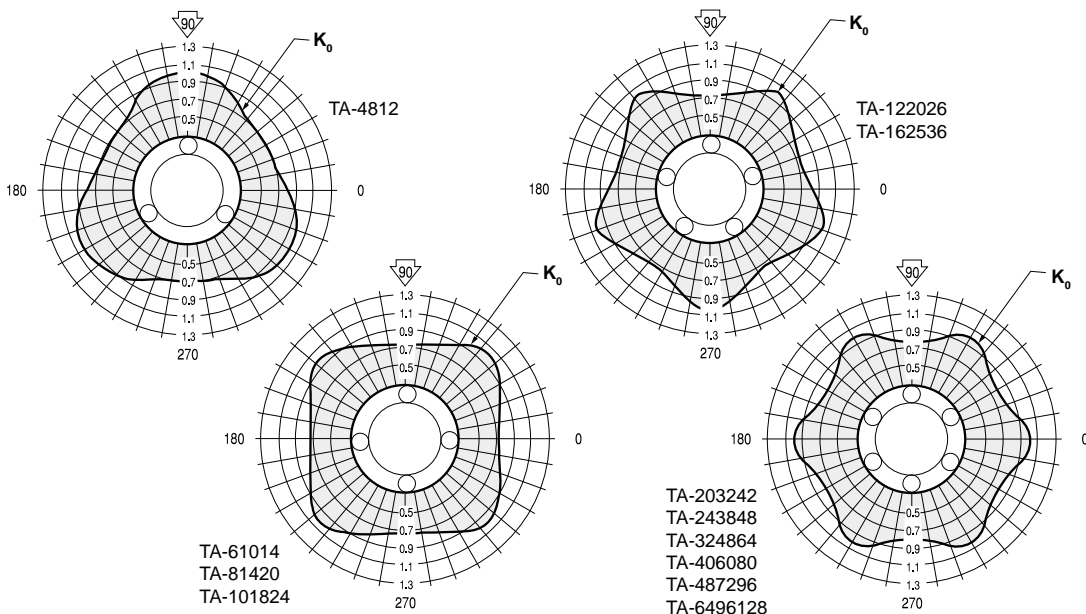

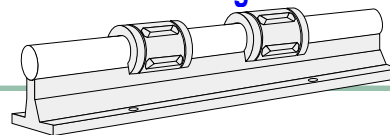

Precision Steel Ball Bushing™ Bearings

(Open Type) for Continuously-Supported Applications

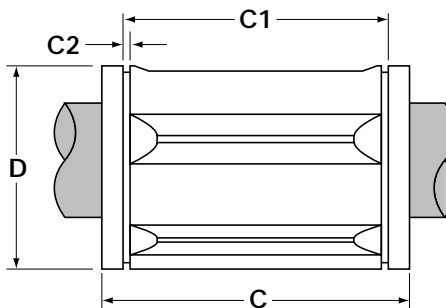
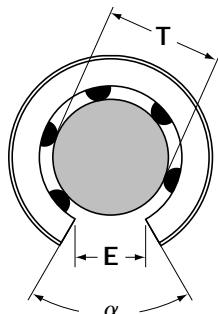

Precision Steel Ball Bushing™ Bearings (Open Type)				
(Dimensions in inches)				
Catalog Number	Nominal Diameter	Length C	Distance Between Retaining Rings C1	Ret. Ring Groove Min. C2
TOPN-81420	.500	1.250/1.235	.967/.951	.046
TOPN-101824	.625	1.500/1.485	1.108/1.092	.056
TOPN-122026	.750	1.625/1.610	1.170/1.154	.056
TOPN-162536	1.000	2.250/2.235	1.759/1.741	.068
TOPN-203242	1.250	2.625/2.605	2.009/1.991	.068
TOPN-243848	1.500	3.000/2.980	2.415/2.397	.086
TOPN-324864	2.000	4.000/3.980	3.195/3.177	.103
TOPN-406080	2.500	5.000/4.975	3.978/3.958	.120
TOPN-487296	3.000	6.000/5.970	4.728/4.708	.120
TOPN-6496128	4.000	8.000/7.960	6.265/6.235	.139

Catalog Number	Working Bore Diameter T	Recommended Housing Bore (Before Adjustment) D	Min. Slot Width E	Angle deg alpha	Number of Ball Circuits	Ball Bushing Bearing Mass lb	Dynamic ^Δ Load Capacity lbf
TOPN-81420	.5005/.4995	.8760/.8740	.31	50	3	.07	60
TOPN-101824	.6255/.6245	1.1260/1.1240	.38	60		.11	105
TOPN-122026	.7505/.7495	1.2510/1.2490	.44	60	4	.17	140
TOPN-162536	1.0005/.9995	1.5635/1.5615	.56			.32	240
TOPN-203242	1.2506/1.2494	2.0010/1.9990	.63	50	5	.90	400
TOPN-243848	1.5006/1.4994	2.3760/2.3740	.75			1.12	600
TOPN-324864	2.0008/1.9992	3.0010/2.9990	1.00			2.16	860
TOPN-406080	2.5010/2.4990	3.7515/3.7485	1.25			4.24	1380
TOPN-487296	3.0012/2.9988	4.5015/4.4985	1.50			7.33	2000
TOPN-6496128	4.0020/3.9980	6.0020/5.9980	2.00			17.25	3800

^ΔSee the chart on the bottom half of the next page.

Continued on the next page

NOTE: Catalog number is for a standard item.

For other options, add: **SP** Stainless Steel Balls, Black Oxide Sleeve and Retainer, **NB** Nylon Balls, **DP** Dry-Packed, **SS** Stainless Steel (.500 thru 1.000 sizes), or **DD** With Integral Wipers, to end of catalog number.



Precision Steel Ball Bushing™ Bearings (Open Type) for Continuously-Supported Applications

Load/Life Graph (Lines indicate limiting load for given BALL BUSHING Bearing)

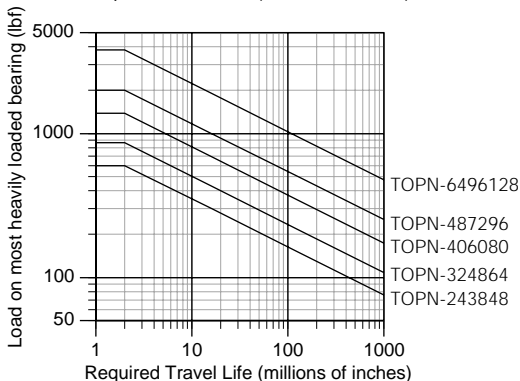
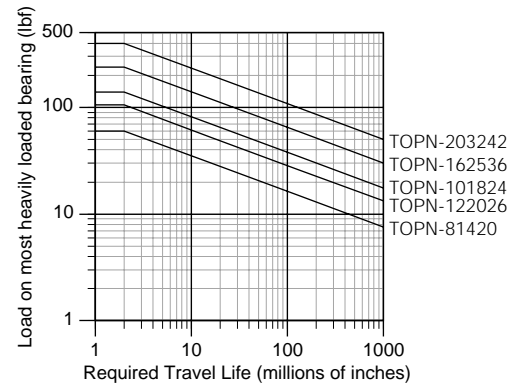

Determining BALL BUSHING Bearing Size

To determine the proper BALL BUSHING bearing size, enter the chart with the maximum load of the most heavily loaded bearing and the required travel life. Mark where the two lines intersect. All BALL BUSHING bearing sizes that pass through or above and to the right of this point may be suitable for this application.

Note: For the purpose of using this chart:

$$\text{Load on Most Heavily Loaded Bearing} = \frac{\text{Maximum Applied Load}}{K_0}$$

where:

K_0 = the Load Correction Factor, which can be determined from the Polar Graph below.

Dynamic Load Capacity Correction Factor, K_0

The Dynamic Load Capacity is based on a rated travel life of 2 million inches. The actual Dynamic Load Capacity can be affected by the orientation of the bearing or the direction of the applied load. For dynamic load Correction Factors, see polar graphs below.

Polar Graphs

The actual Dynamic Load Capacity of a BALL BUSHING bearing is determined by the orientation of the bearing or direction of the applied load. The load Correction Factor K_0 is found by knowing the direction of the applied load relative to the orientation of the bearing's ball tracks and referring to the polar graph. To determine the actual Dynamic Load Capacity, multiply the proper Correction Factor by the Dynamic Load Capacity listed in the product table on the previous page.

